

GLIDING AND SAIL-PLANING

A Beginner's Handbook

by **F. STAMER**

Principal of the Rhön-Rositten Gesellschaft Flying School
and

A. LIPPISCH

Principal of the Rhön-Rositten Gesellschaft Technical School

Translated by

G. E. STARTUP and **FRANCES KINNEAR**



With 84 illustrations.

5s. net.

Ex Libris

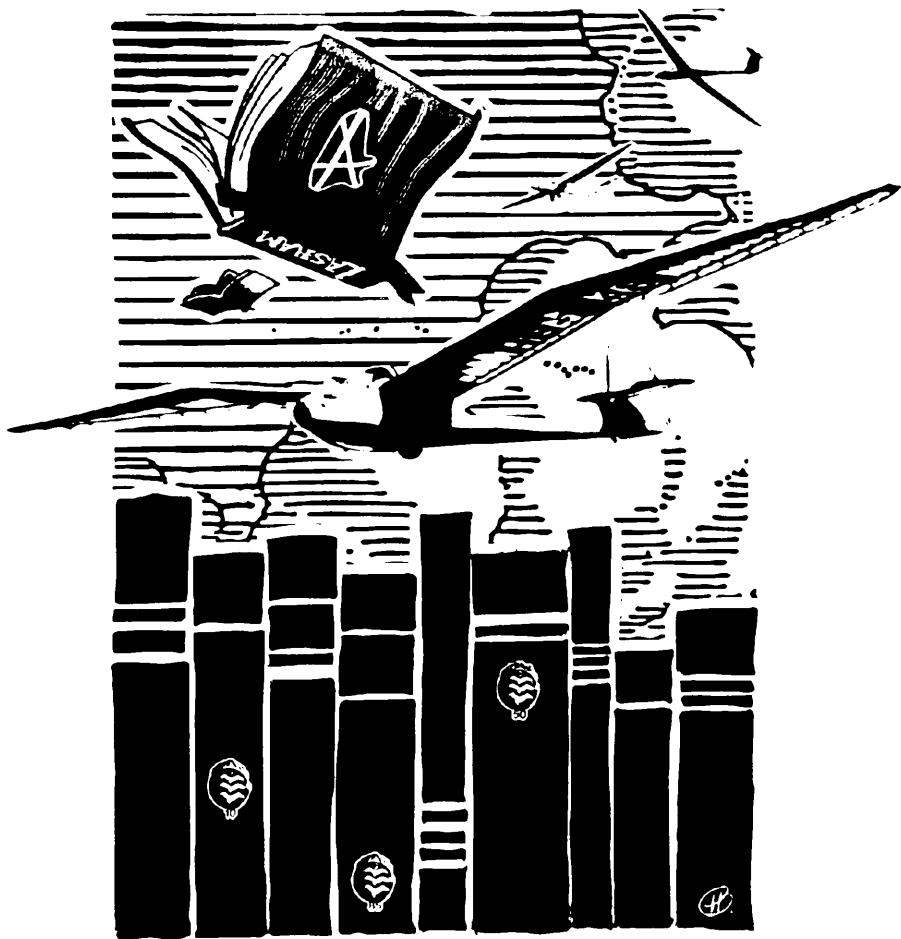

From the Gliding Library of
Wally Kahn

GLIDING AND SAIL-PLANING

GLIDING AND SAIL-PLANING A Beginner's Handbook

by F. STAMER

Principal of the Rhön-Rositten Gesellschaft Flying School

and A. LIPPISCH

Principal of the Rhön-Rositten Gesellschaft Technical School

authorized translation by

G. E. STARTUP and FRANCES KINNEAR

WITH 84 ILLUSTRATIONS AND DIAGRAMS

LONDON

JOHN LANE THE BODLEY HEAD LTD.

English edition first published in 1930

PRINTED IN GREAT BRITAIN BY
THE BOWERING PRESS, PLYMOUTH

Foreword

THE motorless AIRPLANE, i.e. the GLIDER or SAIL-PLANE, is steadily growing in popularity, and is, in the truest sense of the word, the flying sport of youth.

This book represents the collective results of the writers' experiments since 1921 in motorless flight, and particularly in gliding, related in a way most likely to be useful to others. In flying, more than in anything, every experience and triumph individually won by hard endeavour should be triumph and experience won for all. Its aim is to state as clearly as possible all the beginner ought to know of Gliding and Gliding Machines. The theories it contains are explained in such a manner as to be easily understood. The finest airmen are often hopelessly bad mathematicians and Flying as a Sport should, as far as possible, be made easy for everybody.

FRITZ STAMER
and ALEXANDER LIPPISCH.

WASSERKUPPE, RHÖN.
January, 1930.

Some statements in this text are not, strictly speaking, scientifically accurate in detail, but it must be remembered that the writers' aim is to make themselves clearly understood and to convey the right idea.

Contents

CHAP.	PAGE
FOREWORD	vii
I. EQUIPMENT AND TRAINING	I
II. CHOICE OF GROUND	6
(I) FOR BEGINNERS	8
(2) FOR PRACTICE	12
(3) FOR SAIL-PLANING	16
III. TRAINING	22
IV. PRACTICE FLYING AND SAIL-PLANING	27
V. CLOUDS AND WINDS	33
VI. MACHINES	40
VII. TOOLS, CONSTRUCTION MATERIALS AND METHODS	51
VIII. MAINTENANCE OF A MACHINE	69
IX. TRAINING METHODS	85
X. INSTRUMENTS—GROUND AND ON INSTRU- MENT BOARD.	105

CHAPTER I

Equipment and Training

FORMERLY an airman's get-up was an essential part of his dignity, for by his appearance you might know him. To-day, however, it is otherwise, for flying is no longer eccentric and strange, but has become a form of sport and a subject of general interest. Thus, in spite of his glorious achievements, the Air Force Captain has become a normal citizen and no longer appears before his admiring neighbours decked out in his leather helmet, goggles and elegant, high laced-up boots. To-day it is only the beginner who flaunts these insignia in public, and when he ceases to wear them we know that he has already learned a little.

The first thing the gliding pupil needs is a pair of stout boots. Boots, such as ski-ing boots are unsuitable, because in these the action of the foot is clumsy and sudden and a delicate touch is absolutely necessary for steering. Laced-up boots are the

most satisfactory, as these support the ankles in case the airman jumps awkwardly on landing.

A woollen muffler is only necessary in very cold weather, as a gliding flight does not last long enough for any real danger of chill. Every airman should certainly wear a cap, and he will find it better to wear the peak to the back, otherwise it might easily be blown off. A leather helmet with ear-flaps is not to be recommended as it affects his hearing, and this is extremely important. To fly bare-headed is likewise inadvisable as accidents may happen and the head would then be totally unprotected. For this same reason the airman should always put on a jacket and trousers, even in summer, when he is tempted to wear nothing more cumbersome than running-shorts or a bathing-suit. Goggles are not needed in summer, but in winter anyone whose eyes are at all sensitive ought to wear them. They should, however, be made of celluloid or Triplex to avoid any danger of wounds from splintering glass. Shortsighted persons must, of course, wear glasses, but on no account pince-nez, as these would soon be blown off. Anyone using glasses should, in case of accident, try to take them off before the crash, as they are always a source of danger.

A practical garment for gliding is a sports suit. Of course, the sail-planer intending to undertake longer flights must pay greater attention to his clothes. He must be clad in such a way that when he has to sit almost motionless for hours, he will



FIG. I.

not become chilled or stiff. Nothing is more unpleasant on long flights than to feel chilled to the bone. The sail-planer should always wear protective glasses, as he is almost invariably placed so that the level of his eyes is just above the edge of the cockpit, and the draught is, therefore, very keen.

The suit must be comfortable, easy-fitting in every way. Puttees, tight leggings or garters are apt to stop circulation so that the legs or feet "go

to sleep," which may, in certain circumstances, be so serious as to force the airman to land. The boot-tops, too, must fit easily. A clean handkerchief, for ordinary use or for wiping the glasses, as the case may be, should be carried in a handy pocket, and refreshments put where they may be easily reached, since, owing to the smallness of the cockpit there is not much room for hunting through one's pockets. If no clock is built into the cockpit, the airman must fix one in a suitable position in front of him, as a clock is absolutely necessary.

On every flying machine, of any type, the address and telephone number of the airman should be clearly painted on the planes or body.

Both the Glider and Sail-planer should always carry that universal tool, the Combination Pliers, as part of his outfit.

In winter, the airman should find out before starting whether a face-mask or a scarf bound round the head has the effect of blurring the glasses. This can often be avoided by the adoption of another method of protecting the face. There are certain makes of glasses manufactured that do not become dimmed, and there are various preparations to prevent the dimming of motor-car windows and

windscreens which are suitable for glasses. The airman should always protect the uncovered parts of his face from frostbite by rubbing them with ointment. Feet and finger-tips freeze readily. The feet can be kept warm by the simple method of lining the boots with paper, and a pair of thin silk gloves worn under woollen or fur gloves serves to protect the hands.

Much could be said regarding mode of life, dieting, etc. Any man who devotes himself to sport in any form must go into strict training and order his habits accordingly. He must go to bed early in order to get enough sound sleep, should smoke little and give up alcohol entirely. It is quite wrong to suppose that only those forms of sport which require physical skill and strength necessitate strict training. There are other and similar forms of sport which may with advantage be taken up by the airman, as, for example, ski-ing, canoeing, yachting, ice-sailing, cycling, motoring, skating and scouting. Exercise and gymnastics before breakfast serve to keep one in good health. Swimming strengthens the whole body and is refreshing.

A good airman can generally hold his own in any form of light athletics.

CHAPTER II

Choice of Ground

ANYONE who intends to take up gliding or sail-planing must first find suitable terrain. It would be ludicrous to construct a machine and afterwards look round for ground, because the type of country and the prevailing winds must dictate the type of machine to be used.

When selecting ground one must differentiate between :—

Training ground for beginners.

Practice ground for advanced pupils.

Ground for sail-planers.

Occasionally one may be lucky enough to find ground which will meet the demands of two, or even all, of these groups.

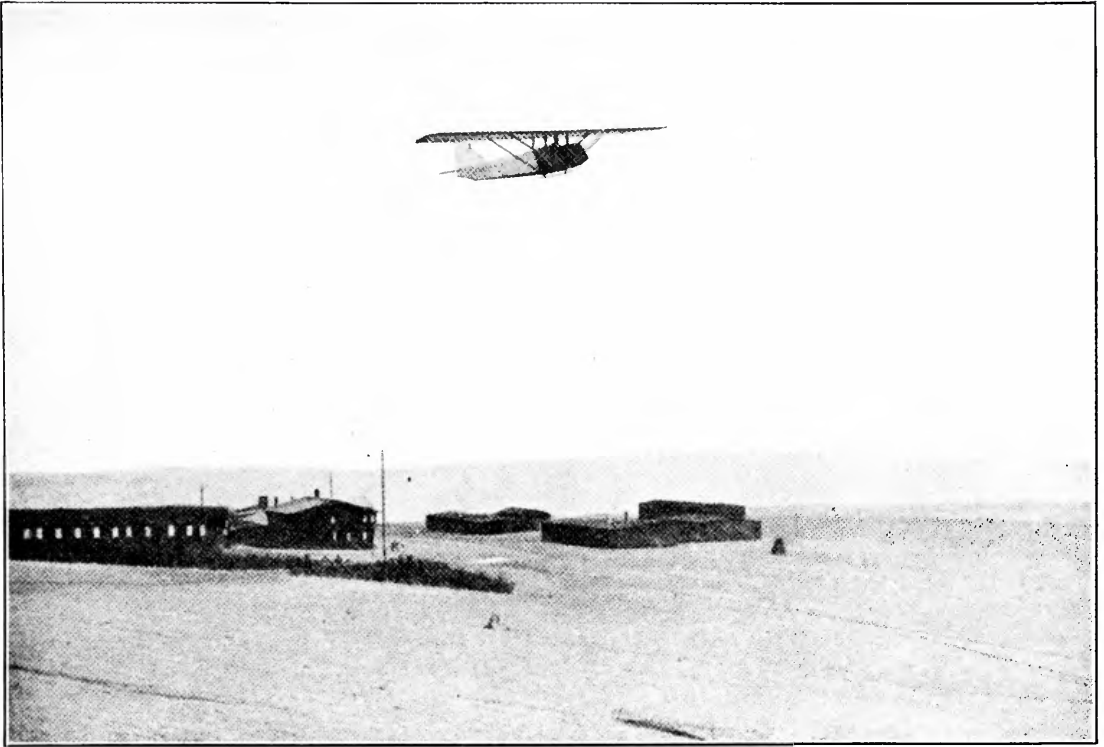

FIG. 2.

“Prüfling” performing a turn. The Wasserkuppe flying slopes are visible in the background.

(I) For Beginners

It is a mistake to insist on steep slopes for beginners. The ordinary machines used in training beginners have a gliding angle of 1 : 12 and can, consequently, accomplish a flight of approximately 300 metres from a height of about 30 metres. Under very favourable conditions the flight of thirty seconds' duration, necessary for Gliding Test A, may be accomplished from such a height. But the consideration which determines the choice of ground must not be whether it is suitable for test purposes, but whether it is safe for beginners. One dare not assume skill on the part of any beginner.

For the sake of the pupil, no ground should come under consideration if obstacles occur on it or along the line of flight within the range of the machine. Stones and boulders must be reckoned as dangerous obstacles, even when they protrude only slightly above the ground. The main consideration is the safety of the occupant of the machine. It must be emphasized that the training course in gliding is comparatively free from risk, if care and prudence are exercised.

In figure 3 an ideal ground is shown in section, indicating the various possibilities which it offers.

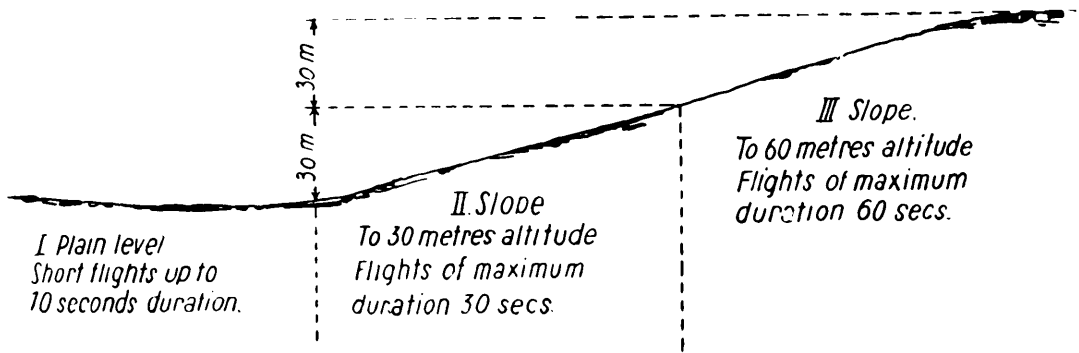

FIG. 3.

A machine in flight over the type of terrain here depicted will never attain a great height. Should he commit an error in steering, the pupil would always reach terra firma before his situation became critical. Not only the altitude of the starting-point, but the angle of the gradient towards the plain are the points which demand careful consideration as determining factors in the choice of ground. An advanced pupil may perhaps be capable of flying over steep slopes, but for the beginner, it is definitely dangerous to attempt anything of the kind.

A special chapter will be devoted to training methods on ground of this type.

The choice of ground depends not only on the nature of the terrain within the immediate range of the flying machine, but on the nature of the surrounding countryside. When considering the advantages and disadvantages of any particular stretch of land, one should try to imagine the air as a fluid flowing across it. Obstacles on the ground cause eddies in the air and deviate it from its normal course, in exactly the same manner as dams, or piles in the waters of a river.

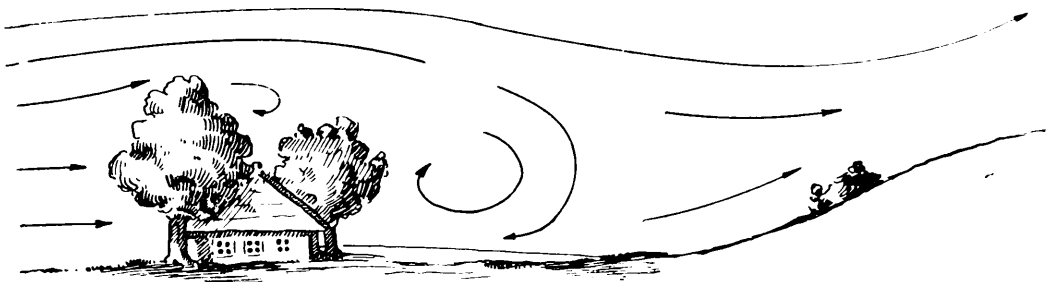

FIG. 4.

Anyone who can visualize the course of this stream, flowing across the countryside, will immediately realize what the sketch shows, namely, that the level ground at the base of the flying slopes should be free from large obstacles, otherwise the eddies caused by such obstacles would develop into unpleasant gusts or downward currents, as shown in figure 4.

Terrain of this type can be used for gliding purposes only when there is a dead calm, as the dangerous phenomena on the lee-side of obstacles do not then occur (see fig. 5).

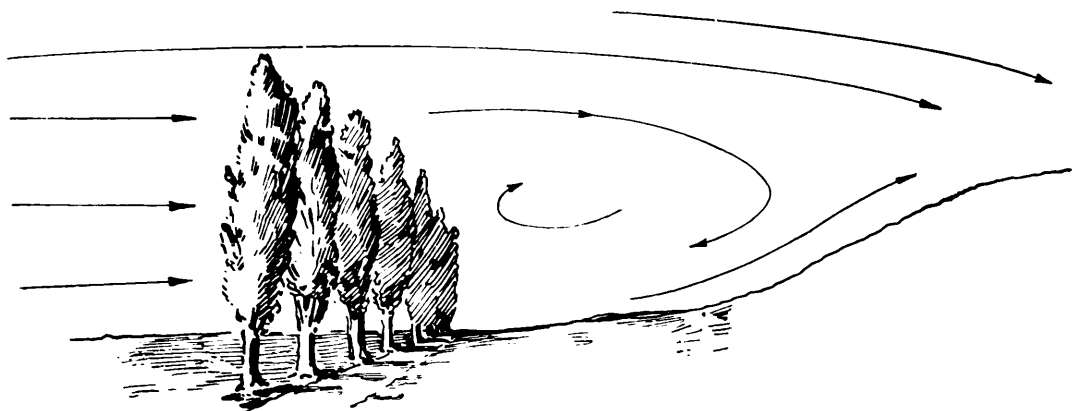

FIG. 5.

Although the training ground used by beginners must be absolutely void of obstacles within the range of the machine, not only along the course of flight, but on both sides thereof, the practising airman ought to be capable of avoiding any obstacles which lie on either side of his path of flight, that is to say, he ought to be able to steer a straight course so that such obstacles cease to be a source of danger for him.

(2) For Practice

When selecting terrain for practice purposes, one may, therefore, assume a certain amount of skill on the part of the airman. A fairly steep slope is quite suitable, but anything in the nature of a perpendicular cliff is to be condemned.

An airman should have obtained Gliding Certificate B, if not a more advanced certificate, before attempting practice flights.

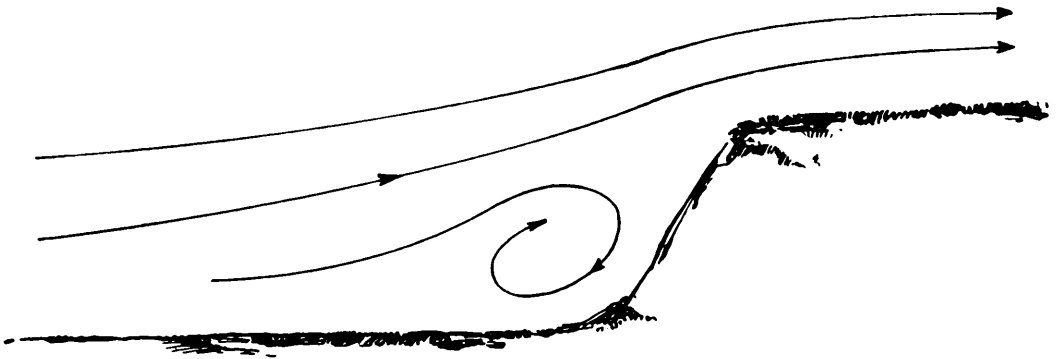

FIG. 6.

Even if the airman has become expert enough to fly over steep slopes or cliffs, he is liable, in a strong wind, to encounter unpleasant and even dangerous whirlwinds at such places (fig. 6).

In no circumstances must the landing-place in front of such slopes be hemmed in by obstacles which might render a normal straightforward gliding descent impossible.

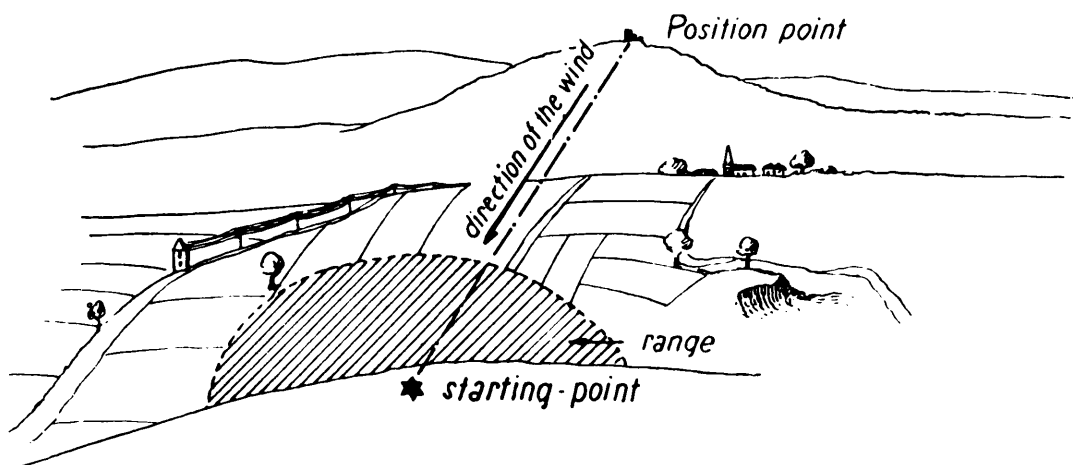

FIG. 7.

The ground must be void of obstacles within the range of the machine.
The position point is chosen in the direction from which the wind is blowing.

Any slope where a landing must be accomplished within a small area surrounded by trees, houses, rocks, telegraph poles, etc., is unsuitable as practice ground.

An airman, must, as a matter of course, learn to avoid obstacles and to perform test landings within a given small area, but he should not practice in the vicinity of actual obstacles. Certain spots on the ground can be marked with little flags to indicate that they are to be regarded as obstacles.

Actual obstacles situated at the base of the slope in such a way that the airman is forced to fly over them are a source of grave danger.

It must always be borne in mind that an unfavourable wind or a sluggish start may cause the machine to fly very low over the ground. In such cases, the smallest obstacle becomes a source of real danger, as a gliding machine attains a not inconsiderable speed. Every accident injures the cause to an extent that many successful feats cannot undo !

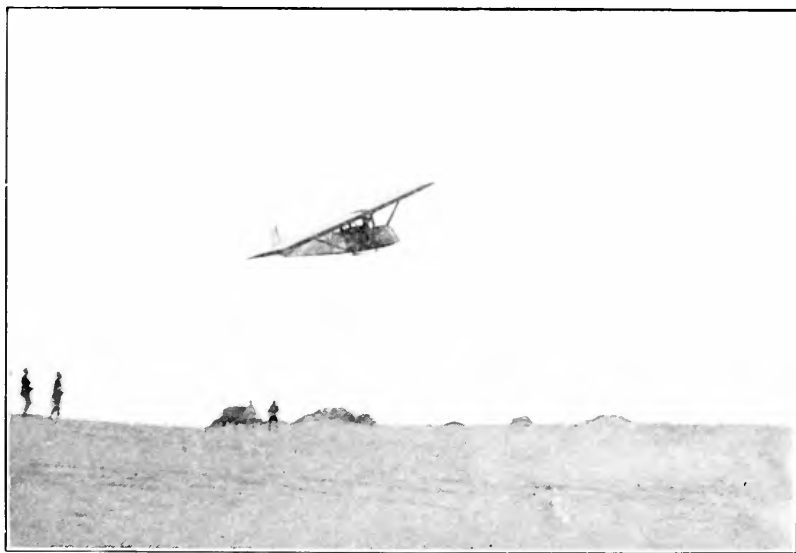

FIG. 8.

“Prüfling” performing a turn after the start.

In Germany there exist a number of organizations, such as the “Deutscher Luftfahrt-Verband e. V.”,

the "Deutscher Modell-und Segelflug-Verband," the "Rhön-Rossitten-Gesellschaft e. V.," any of which will, on application, send an expert to view and value ground for flying purposes. It is advisable to make use of such a service, as considerable trouble and expenditure can be avoided in this way.

(3) For Sail-Planing

There is a great difference between the type of terrain used for sail-planing and the ground already described as suitable for beginners and for practice. As the term implies, the object in sail-planing is to maintain one's elevation as long as possible, at the altitude of the starting-point, if not even higher. The airman glides parallel to the hill, doubling back and forth across the face of the slope, which must therefore be a long one. The longer the extent of the slope, the easier it is for the airman to remain in the air. The machine loses altitude at each turn and continual turning tires the pilot.

The long slope chosen for sail-planing should rise at least 20 to 30 metres above the average height of the surrounding country. This will insure a strong up-current of air and the wind will blow directly against the hill slopes. If there are other heights in the neighbourhood they may afford an unwelcome screen against the wind or even cause a downward current of air on the sail-planing slope (see fig. 9).

Obstacles occurring in front of the slope have the additional disadvantage that they may cause the

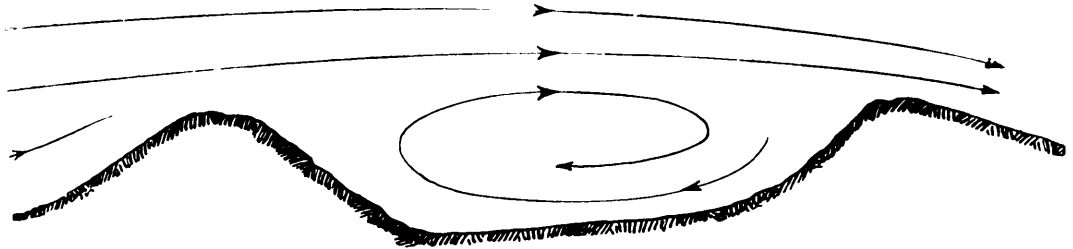

FIG. 9.

approaching air currents to palpitate to such an extent as to prevent the development of an up current. Only in very rare cases are the neighbouring slopes so fortunately situated that when the wind attains a certain velocity, the palpitating masses of air receive a fresh impetus on each ridge so that on the sail-planing slope itself the up current

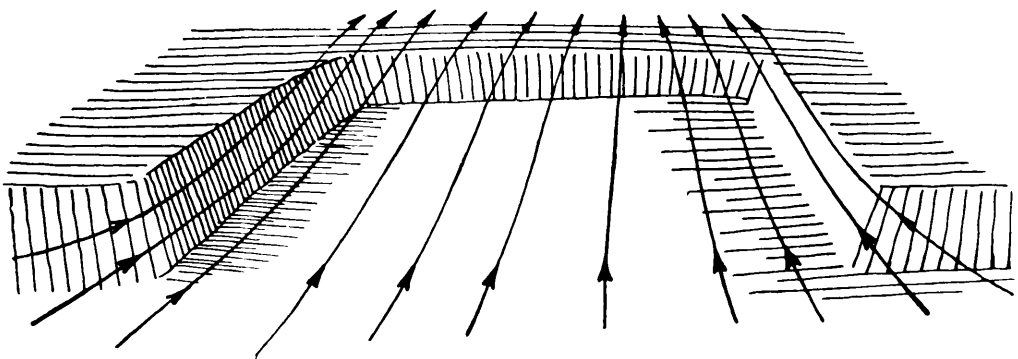

FIG. 10.

acquires additional force, like a breaker when the tide is flowing.

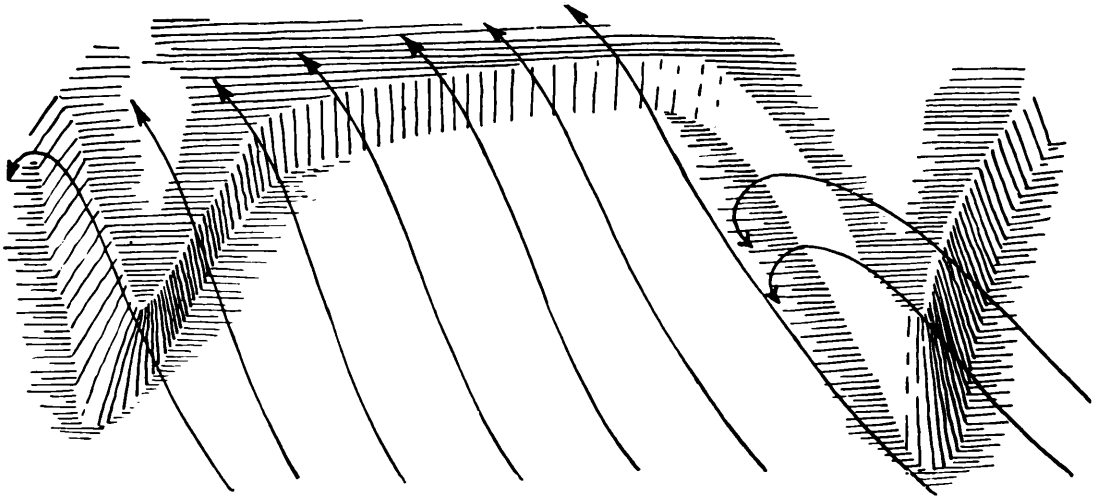

FIG. 11.

The wind conditions are usually very favourable on slopes curving in the form of an open horse-shoe, which face the wind and cause it to flow along a narrowing channel towards the sail-planing slope, where it develops into an intense up current. This type of terrain has the additional advantage that the turning-points at either end of the sail-planing slope will lie almost entirely within the area of the upward current, instead of slightly outside it as on an open hillside (see figs. 10 and 11).

When sail-planing over terrain of this horse-shoe form, the airman must observe the course of the wind with great care, since if the wind is not blowing directly against the face of the slope, it may flow up and over the hill spurs in such a way that parts of the slope lie in lee or even in a downward current.



FIG. 12.

Covered-in cockpit to minimize wind-resistance.

When choosing terrain for sail-planing one must, as when selecting ground for gliding, take into

consideration the prevailing winds in the district. Terrain otherwise pre-eminently suitable is practically worthless, if the wind seldom blows directly on to it.

In the case of an airman who takes up sail-planing, one may assume that he is able to start from one particular spot on the slope, but at the same time there must be an adequate number of landing-places within the range of his machine. A sail-planing slope is seldom so devoid of obstacles that the airman can land anywhere and everywhere.



FIG. 13.

Soaring above the slopes of the Wasserkuppe.

We assume that the sail-planer is in possession of Sail-planing Certificate C.

Having discovered suitable terrain, one should attempt to obtain statistics on the average velocity of the prevailing winds. These statistics may be obtained from a meteorological observatory such as exists in certain schools or colleges, but failing these, reliable information can often be gained from people such as farmers, shepherds or fishermen, who are accustomed to observe the signs of the weather. Such information is of essential importance, since it dictates the choice of machine. There exist machines specially constructed for use in a light wind and others for use in a strong wind.

Having accumulated detailed information regarding weather conditions, one should once more apply to the D.L.V., the D.M.S.V., or the R.R.G. for expert advice on the selection of a suitable type of machine.

CHAPTER III

Training

THE beginner receives his first instruction on level ground. The impetus given by the starting-rope is calculated to allow the machine to "take off" at the correct flying speed. If the impetus, and consequently the speed of the machine, were greater it would be possible for the pupil, through faulty steering, to cause the machine to rise into the air, and so find himself in a critical situation. A machine given the correct impetus will descend immediately after the start, if the control lever is pulled over. As the absolute beginner cannot "sense" the correct tension of the starting-rope, the instructor prompts him, but allows him, if possible, to utter the actual words of command himself. In this way, the pupil knows exactly what is happening, and is not taken by surprise when his machine finally leaves the ground.

Before every start the pupil must carefully station his starting-crew, set the steering controls at normal and give the signal "Ready!" followed by the other commands, "Pull!" "Run!" and "Let go!" The flying instructor observes not only the position of the machine during the flight, but also the position of the various rudders, so that when he delivers his official criticism (the pupil's class-mates pronounce their criticism freely but quite unofficially) he can say not merely, "The machine side-slipped to the left," but "The machine side-slipped to the left because the left aileron was too much depressed, while in a well-meant but misguided endeavour to correct this fault, the rudder was pushed too far to the right, so that the machine 'pulled' somewhat. The correct procedure would have been to leave the rudder in normal position and to move only the left aileron. The aileron alone, never the rudder, should be used to correct side-slipping!"

The pupil must continue to practise very short flights on level ground, until he is thoroughly capable of maintaining his machine in correct position and has become accustomed to the sudden increase in speed given by the impetus of the starting-rope.

At the start, the pupil must sit firmly on the

machine, leaning against the back-rest, for, if there is a space between his back and the back rest, he will, at the word "Let go!" receive a nasty backward jerk, which might cause him to jerk the control lever backward or cause his foot to slip off the rudder bar.



FIG. 14.
Correct position in beginner's
machine.

It often happens, especially when several beginners are training together, that each is anxious to accomplish the highest and longest flight. Let it therefore be clearly understood that the test of a good flight lies neither in its length nor in its height. On the contrary, it is almost invariably true that the pupil whose flights from level ground were "so beautifully high," does not progress so rapidly when it is a question of flying on a somewhat higher slope. As he gains in proficiency, the pupil may venture cautiously, metre by metre, higher up the slope. A good training ground which permits of this gradual progress, is well worth the money spent to procure it.

When the pupil can accomplish successive faultless straight flights from the high slope, he may carefully and cautiously proceed to practise turns, half-way up the slope.

The pupil first flies straight ahead for a short distance. If the machine (and every rudder) is in correct position, the turn is begun by moving the directional rudder by means of the rudder bar. This having been accomplished, the aileron is slightly elevated on the same side, but very cautiously and with extreme care. The rudder bar is then brought back to normal position and by means of the oppo-

site aileron the machine is also brought back to a horizontal flying position. This order of procedure must always be observed. The use of the directional rudder is of the greatest importance, for a turn is, when all is said and done, neither more nor less than an alteration of the course. The aileron is used as an auxiliary. Care must be exercised at the commencement of the turn to prevent the machine from side-slipping in the opposite direction, through the use of the rudder, and at the finish of the turn the rudder bar must be brought back to normal position, so that the aileron is not pulling counter to the directional rudder.

The beginner should accomplish all turns with a wide radius and without allowing the machine to bank very much. Steering change turns are to be avoided. They are not necessary in gliding and sail-planing, and come, strictly speaking, under the heading of trick flying.

CHAPTER IV

Practice Flying and Sail-Planing

HAVING discussed training and gliding in the foregoing chapters, we will now deal with practice flying and sail-planing. The object of practice flying is, as the name indicates, to keep the airman in form and to afford him an opportunity for becoming more proficient in the art of flying. Even if he does not entirely forget the art of flying, during a period of inactivity, he will find that he is out of practice and may even be at a loss to know how to manage a newer type of machine. Every airman should, therefore, continue to fly to keep himself in practice and should also fly the most modern types of machines, in order to keep pace with the progressive evolution of sail-planing.

He should, at the same time, set himself test exercises of steadily increasing difficulty. Progress can be made only with great patience and extreme

caution, especially when the airman has just graduated from gliding to sail-planing.

The airman who has passed Gliding Test B should, after he has practised and thoroughly mastered the art of turning, attempt to bring his machine into position, so that it lies in an upward air current. His course of flight will then almost invariably resemble a figure eight and the turns must always be performed against the wind. He should never, even at a considerable distance off the face of the slope, yield to the temptation to perform turns with the wind, as it is impossible to turn the machine sharply when very close to the ground and he runs a grave risk of crashing against the hillside.

One of the main difficulties experienced by the airman in his initial attempts at sail-planing, is the so-called "start-turn." It is necessary to commence the turn immediately after the start, to prevent the machine from getting beyond the often very narrow area of the up current. If this did occur, a sail-planing flight would be impossible. An expert airman can push out the rudder bar, before detaching the starting-rope, and then as soon as the rope is released, cautiously use the right or left aileron, as the case may be.

As a sail-planing machine always betrays a certain inertia in turning, the airman, being very close to the slope, must exert extreme care and great caution in order to perform the turn at the correct moment.

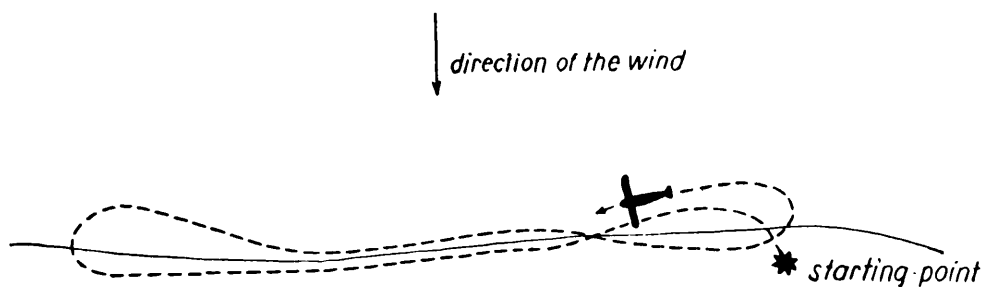

FIG. 15

Figure 8 course in front of a slope, as seen from above.

The start turn is rendered easier, if the airman instead of taking off directly up wind, brings his machine into a position facing slightly across wind, in the required direction.

If the terrain is of the nature which has been described as ideal, i.e. with ridges flanking the actual planing slope on either side, turns may be performed with a wider radius. This is also possible in a superior type of machine, which loses very little altitude, even when it gets beyond the up current. At the same time, anyone using a less powerful machine should never attempt to perform very acute turns, but should only allow the machine

to turn in such a way that it can be brought immediately into normal position without having to depend upon the rudder. The greater the wing span of a machine, the greater its inertia !

Assuming that the up current is sufficiently strong and that the machine is kept in correct flying position, it will begin to soar. For ordinary sail-planing along a slope, it is only necessary to remain within this particular wind zone. It is usually the case that at a low altitude the airman experiences fairly strong gusts. But, if he can gain in altitude with the help of a favourable wind, the gusts will cease and he can then fly in greater comfort and safety.

When flying over fissured ground the airman's first care should be to attain the so-called 'upper layer'. This may be described as follows: there are always slight ascending and descending eddies of wind immediately above any section of the earth surface, which contains clefts and fissures, but above these eddies there passes a great, compact up current which makes itself felt on the lee side of hills, in the form of a downward sweeping current. If, therefore, an airman succeeds in reaching this upper layer, he will not be subjected to continual vacillations in speed and can, moreover, fly with greater

ease and freedom, as he need no longer observe the earth surface at an altitude at which slight downward currents are imperceptible.

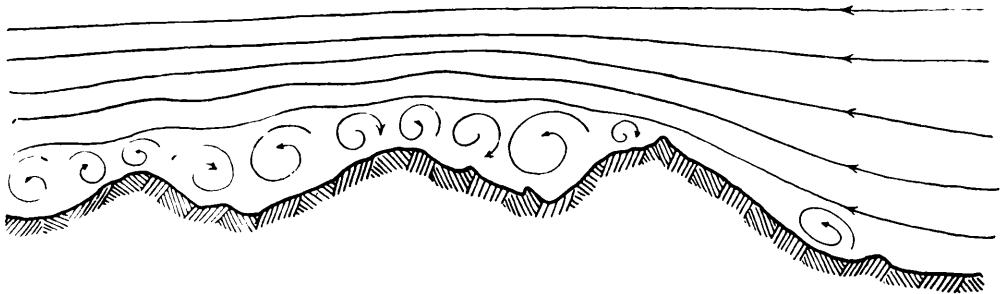

FIG. 16.

In the upper layer the airman encounters a compact area of up currents.

If the airman does not encounter strong currents or gusts, he can, by steering a good course, attain the extreme altitude of which his machine is capable in this particular wind speed and may even risk a long-distance flight. To do this, it is essential for him to gain sufficient altitude to allow him to reach, by gliding, the next hill where there is an up current of air, and so on.

It is vital that this type of sail-planing should be practised by sail-planers in the earliest as well as in the later stages, as it teaches them how to handle the machine and affords an excellent opportunity for practice. Only after he has completed several flights of this description and feels himself abso-

lutely safe in the machine, should an airman attempt more difficult feats, such as the style of cloud flying now used in long-distance soaring. Cloud flying may entail very critical situations which test airman and machine to the uttermost and everyone should be made well aware of this before he makes the attempt. If an airman reaches a strong current ascending to clouds he cannot forthwith end his flight, as such a descent would involve a greater strain than his machine could bear. More difficult flying feats, such as flying among clouds, will be discussed elsewhere.

CHAPTER V

Clouds and Winds

THE great thing for an airman, the thing that matters most to him, is the wind—the air currents that have to be taken into consideration in every type of flying. Of all branches of flying, sail-planing is the one most affected by atmospheric conditions.

Just as it is the sailor in a sailing ship who can best get to understand and know his own particular elements, wind and water, so it is the man in the gliding machine who comes into closest contact with his element, the air, and as a captain of a liner ought to have learned to manage a sailing ship, so everyone who aspires to fly an engine-driven aeroplane should have had previous experience of gliding.

In flying it is much more than the mere question of a favourable or unfavourable wind. Its eddies and its deviations from the normal course involve

danger for the airman who must know them thoroughly in order either to meet or avoid them.

Air-currents are caused by the varying temperature of the atmosphere, which, in its turn, causes variations in atmospheric pressure. The natural result of these variations is that the air is set in motion and disperses in the direction of those regions where the atmospheric pressure is lower.

Varying atmospheric temperatures and consequent varying high pressures are caused by the unequal heat of the earth's surface which imparts some of its heat to the air. Thus is brought about an expansion of the air which has been warmed by the surface of the earth. This volume of air tends to rise and presses against the air of normal temperature immediately above it, so that the atmospheric pressure is increased. On the other hand, if a certain part of the earth's surface is cooler, owing to moisture or for any other reason, the effect will be exactly the reverse.

An increase or decrease in temperature causes the formation of undulating layers having the same atmospheric pressure, which are not consistent with the equilibrium of the atmosphere.

Thus the air, following the same trend, flows away from the warmer zone towards the cooler surrounding area. Owing to this flux, the atmospheric pressure will tend to decrease over this particular area, and to increase in the cooler area,

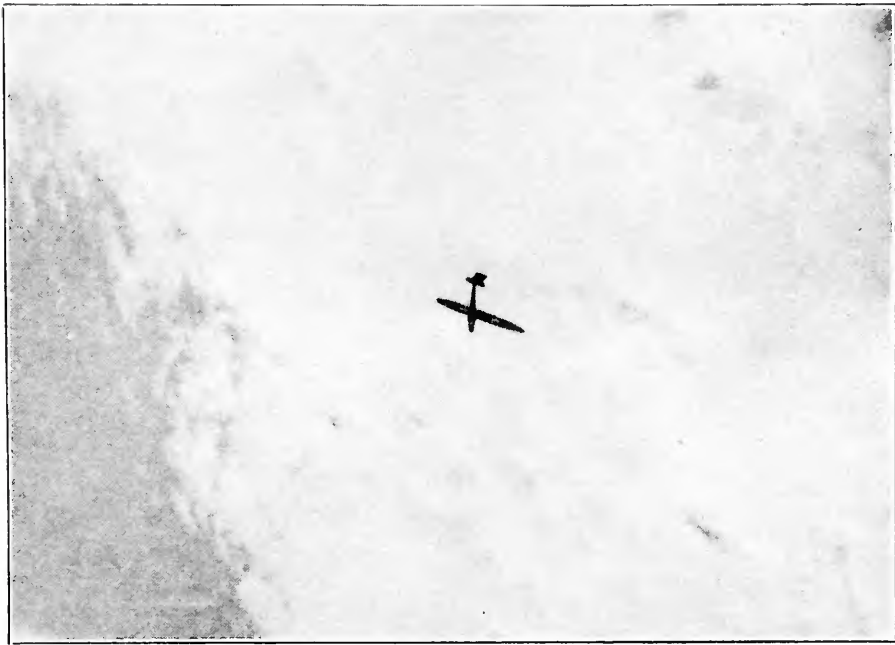

FIG. 17.

Sail-planing under clouds. (To gain a clearer impression, hold the illustration above the head, in a horizontal position.)

owing to the influx. These variations in temperature on the earth's surface cause further movements in the air, since from the cooler part of the earth's surface, where the atmospheric pressure is increasing, the air will flow towards that area where the pressure

is decreasing, namely, the warmer part of the earth's surface. The result of these variations in temperature is that the air flows away from a warm region, except immediately above the surface of the earth, where it flows towards the warm area. This circulation of the air occurs invariably where different temperatures meet—most frequently between the torrid and the cooler zones or between land and ocean. Those winds which enable the airman to fly over obstacles are particularly interesting, as they are frequently caused by thermal currents.

Certain cloud formations denote an up current of air. Moisture borne upwards from the earth condenses at a considerable height, forming a cloud. Every cloud of cumulus or wool-pack formation thus denotes a warm draught or current, such currents being particularly prevalent over towns, heights and open country.

The upward air currents are extremely strong underneath single cumulus clouds. These winds have recently played a tremendously important part in the progress of sail-planing, as they render possible feats in altitude and long-distance flying. It is possible to maintain oneself in flight, under large cumulus clouds and thus to fly for long dis-

tances over level country and even to fly over the lee side of a hill range, without losing altitude.

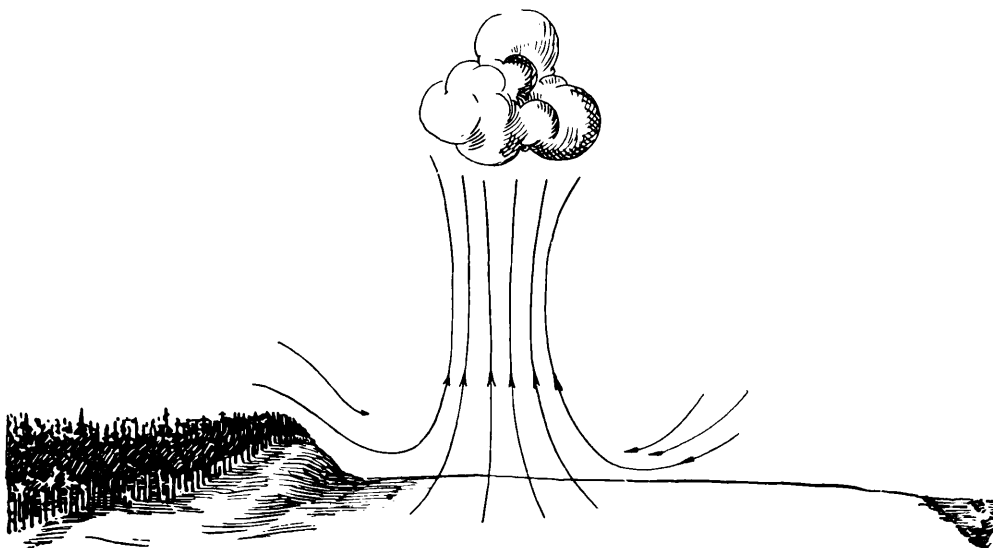

FIG. 18.

A cumulus or wool-pack formation above a warm up current.

In weather conditions peculiarly favourable for sail-planing, whole chains of cumulus clouds sometimes form, so that it is possible for the airman to patrol their entire length. A particularly favourable cloud formation consists of those clouds which are piled up above a straight base. Clouds which are just forming and perhaps consist merely of delicate wisps, frequently indicate a strong upward current. It has been found possible, in a superior machine, to surmount the cloud by means of the up current in front of it, and thus to soar above the cloud.

Everyone who means to attempt cloud flying should bear in mind that strong gusts are frequently encountered below clouds. The airman must therefore be sure of himself and of his machine before making the attempt. The usual method is to soar in the upward current on a slope and thence to reach the warm wind rising to a fairly large cumulus formation. In this manner an airman may be borne upwards to the very base of the cloud itself.

Thunder-clouds denote a very strong upward current, but also very strong gusts. Only an expert and experienced airman dare attempt to fly under these conditions, and even he must exercise extreme caution. In any case, a machine used for such soaring flights must be fitted with reliable instruments, as the airman must reckon on being drawn up into the clouds. During one of his cloud flights, Kronfeld observed hundreds of butterflies which had been borne upwards in the warm air to a great height.

Ideal sail-planing conditions arise when, over an extended area, cold air currents force their way, wedge-like, underneath the warmer layers of atmosphere, making them rise off the ground. The result is that over a considerable area there is a strong upward current which renders long-distance flights

possible. Usually such a cold air irruption is marked by a plainly-defined bank of clouds, which forms at a considerable height owing to the condensation

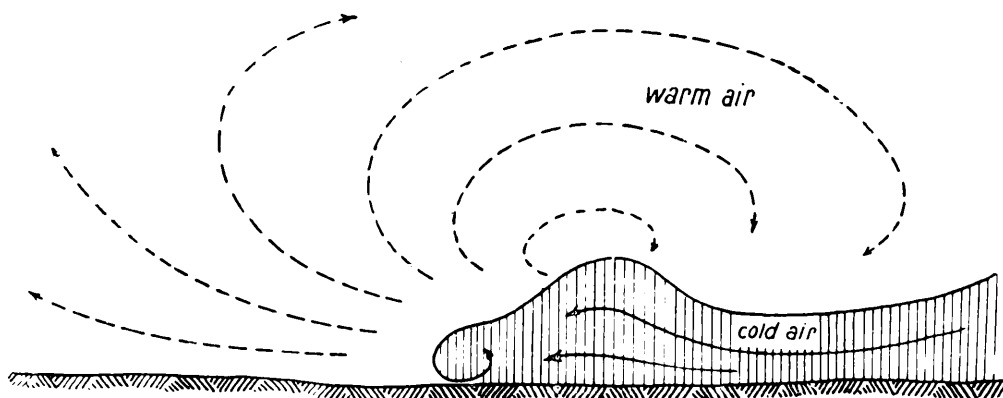

FIG. 19.

Wedge of cold air forces its way under the stationary warm air.

of moisture borne upwards by the warm air. The airman can fly along such a bank of clouds in exactly the same manner in which he flies along a range of hills.

More detailed information regarding the meteorological principles of sail-planing can be found in Professor Georgii's booklet "Der Segelflug und seine Kraftquellen im Luftmeer," published by Klasing. But enough has been said here to make it obvious that the possibilities for sail-planing on hill slopes are by no means exhausted, and that the art of sail-planing is yet in its infancy and has enormous possibilities.

CHAPTER VI

Machines

FOR self-tuition a monoplane is generally used nowadays.

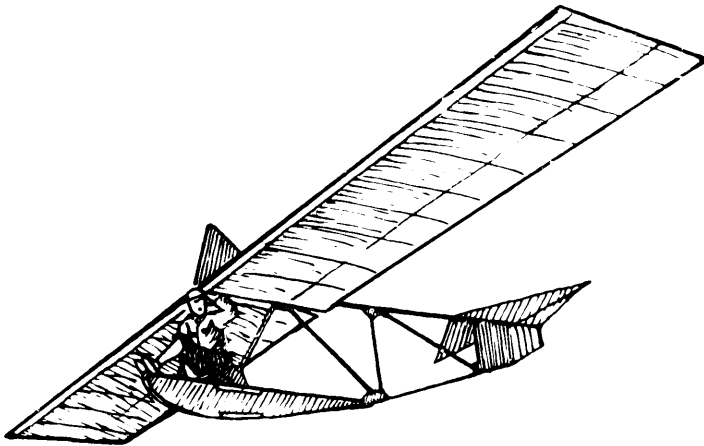

FIG. 20

“Zögling,” belonging to the R.R.G., in flight.

The type of machine originally designed for beginners was the “Hol’s der Teufel,” 1923 (see fig. 21). Until then, biplane models after the pattern of the “Frohe Welt” had always been used.

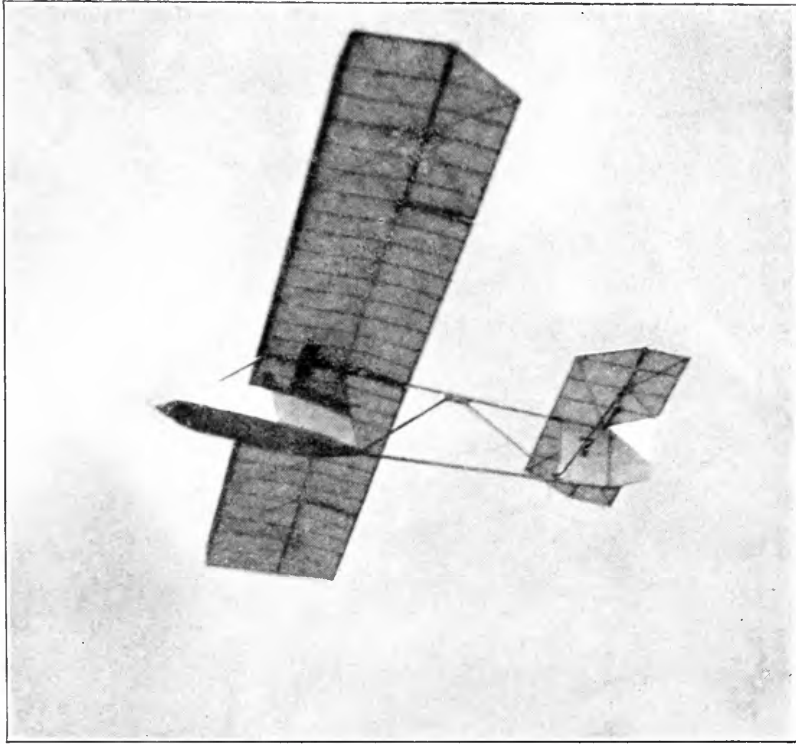

FIG. 21.
“Hol's der Teufel.”

These double-decker machines were found to be very satisfactory for training purposes, except for the fact that ordinary breakages proved rather costly to repair, as two instead of one wing were broken on each occasion.



FIG. 22.
"Pegasus," 1924.



FIG. 23.
Two-seater "Mecklenburg" belonging to the Mecklenburg Aero Club, Rostock.

The open lattice-work body found immediate favour, when it was introduced, because, apart from its more moderate cost, this pattern had the advantage of being easy to overhaul and to repair.



FIG. 24.
Practice machine "Bremen," 1923.



FIG. 25.
Machine for use in slight wind. Property of the R.R.G.

The open pilot's seat was another improvement as the risk of injury from splinters in case of a crash was thereby considerably diminished. For this same reason the support, which in the models "Pegasus" and "Hol's der Teufel," was situated before the pilot, was abolished in machines of the "Zögling" type.

The machine designed by the Mecklenburg Aero Club, for dual control tuition, also bears a close resemblance to its prototype, "Hol's der Teufel." From this same model the so-called moderate-breeze machines were evolved. These machines are capable of flying with a gentle breeze and are at the same time of a simpler build and much less costly than the ordinary machines of superior type.

The "Hangwind" and its successor, the "Prüfling" superseded the older "Bremen" type of machine. In these later models, special attention was paid to steering arrangements, and they were constructed, as far as possible, on the same lines as the ordinary engine-driven aeroplane, to meet the requirements of the air pilot who took up sail-planing or of the man who regarded sail-planing as a preliminary to aeroplane instruction. The proportions of this machine render it unsuitable



FIG. 26.
Practice machine "Hangwind," 1924.

for long flights. The designer was aware of this, but his first concern was to construct a machine which would turn easily. Apart from this, the pupil should not have things made too simple for him and it is excellent practice for him if he experiences some difficulty in holding a straight course when planing in an upward current.



FIG. 27.

“Prüfling” belonging to the R.R.G., after the start. Official observers in the foreground.

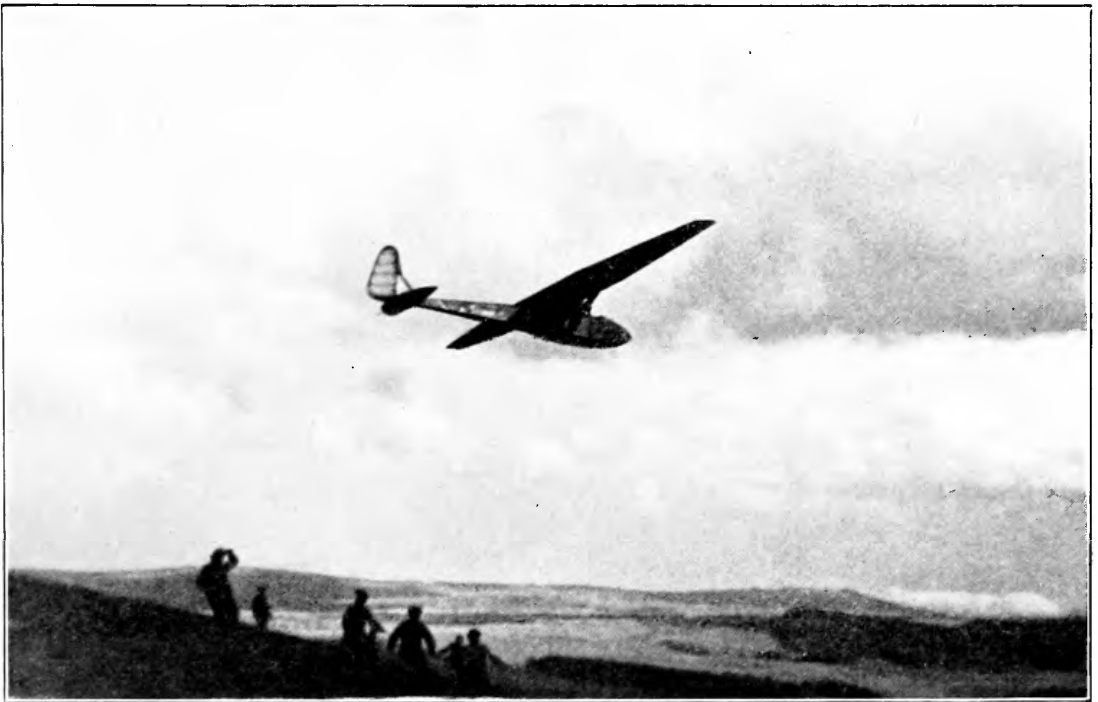

FIG. 28.
Superior machine of the "Professor" type owned by the R.R.G.

The "Professor" model was intended to meet the requirements of airmen who had obtained a "C" grade certificate. This machine, combining as it does, the characteristic advantages of a first-class flying machine with easy manipulation, is eminently suitable for practice in distance flying.

All machines are subjected to very severe reliability tests in order to minimize the risk of breakage through faulty steering or clumsy landings.

Design drawings of the above-mentioned machines, which are now generally used for training purposes, may be obtained on application to the Rhön-Rossitten-Gesellschaft e. V. Certain clubs use other machines, which, however, closely resemble these models.

CHAPTER VII

Tools, Constructions, Materials and Methods

IT is not our intention here to discuss all the tools and materials required for the purpose of constructing a machine. Lists of the necessary materials accompany all drawings or designs of a plane and detailed information on this subject may also be found in the volume "Gleitflug und Gleitflugzeuge" ("Gliding and Gliding Machines"). Our aim is merely to stress certain noteworthy points.

Anyone engaged on the construction of a machine will find that there are many occasions when it is impossible to use an ordinary adjustable clamp, either on account of its weight or more frequently from lack of space. The type of steel clip used by picture-frame makers may be substituted and can be adjusted by means of special pliers.



FIG. 29.
Double-seater training machine of the R.R.G.

The wooden ribs of the plane are cut from a board of the required length, on a cutter head. The usual thickness is 4 by 6 millimetres. Small finely-toothed circular saw-blades are affixed to the perpendicular shaft of the cutting machine, at intervals of 4 millimetres (see fig. 30), and thus a number of rib strips can be cut simultaneously. The method of forming the ribs by means of a template is described in "Gleitflug und Gleitflugzeuge" ("Gliding and Gliding Machines"). If several machines have to be built it is advisable to have a special case for ribs, so that a large number may be prepared at one time and stored therein. But when packing the ribs, care must be taken to place paper between each, as there is a likelihood that some glue will ooze out.

A sufficient number of ribs having been prepared (it is possible to make as many as twelve at one spell), they are pressed together on a template by means of a cramp frame. The template must be varnished over with linseed oil, so that the glue exuded does not cause the ribs to adhere to it. Ribs manufactured in this manner are never nailed. If they are well glued the use of nails is unnecessary.

As a matter of fact, no nails should be left in any

wooden section of the machine, as they rust and destroy the grain of the wood. It is also impossible to use brass nails when constructing a machine of the dimensions of an engineless air plane, as brass nails, being thick, would likewise destroy the grain. Brass-coated iron nails are as liable to rust as ordinary iron nails. When the use of nails is absolutely unavoidable, as for example when affixing the planking to the skeleton ribs of the body work, one may hammer in nails through narrow fillets, strips of ply wood or cardboard, so that they may be withdrawn easily by means of pliers after the glue has dried.

When fabric must be glued on to wood (on the wings, for instance), the surface of the wood is purposely left rough and unplanned, as the glue will then hold better. Size may also be used for this purpose, but the type of glue procurable from cello makers is more satisfactory and is damp-resisting.

Many hands are required to assist in mounting the fabric on the wing frame, as the work must be accomplished with dispatch, since the glue dries very quickly. Strictly speaking, seams in wing fabric should always be made to run along the ribs.

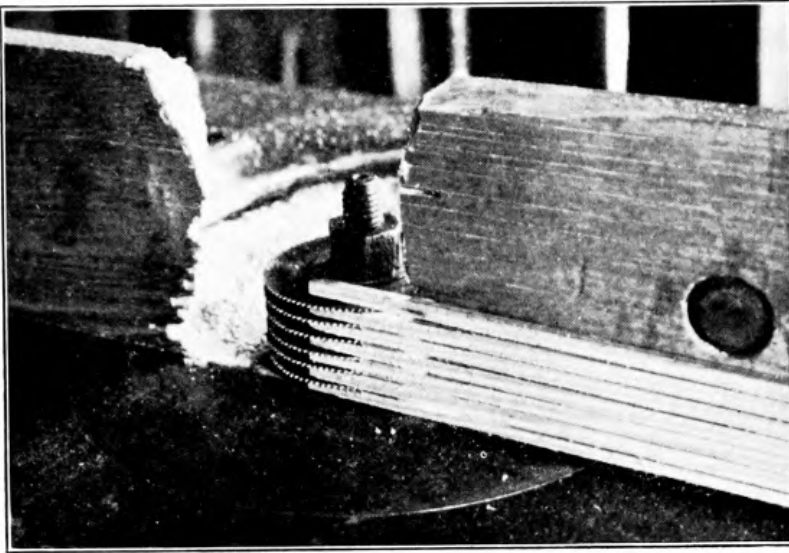

FIG. 30.
Cutting the ribs.

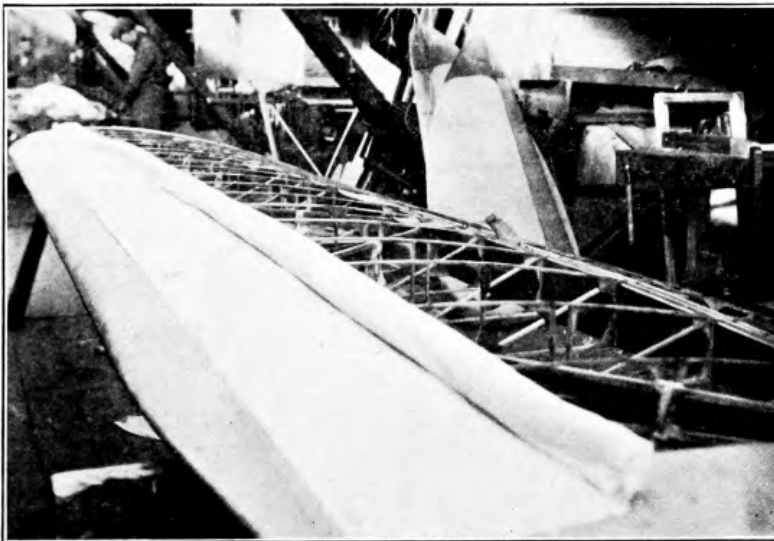

FIG. 31.
Mounting the fabric.

But, as no great strain is placed on the wing fabric of a glider or sail plane, it is generally stretched so that the seams lie at right-angles to the ribs. This method saves both time and labour. The selvedge of the fabric is glued to the leading-edge of the wing and the fabric itself rolled round a long stick. Several persons then set to work to give the ribs a good coating of glue, after which the fabric is unrolled and stretched taut over the framework.

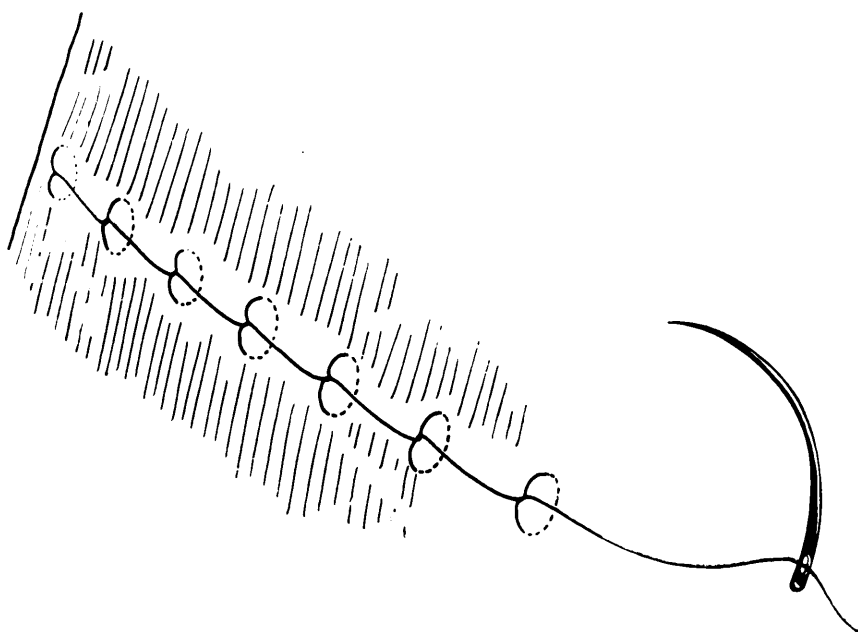

FIG. 32.

Correct method of stitching fabric to ribs, with a bent needle.

A neat and satisfactory method of holding the fabric in place is to stitch it on to the ribs. The ribs are bound with strips of material about 20 to 30

millimetres in width, after which the fabric is fixed in position with pins and then stitched fast along the ribs (see fig. 32).

The underside of the wing should previously have been treated with spirit varnish, as a protection against damp. Care must, however, be taken not to allow any varnish to drop on to the ribs, as it would be impossible to apply glue on top of the varnish when mounting the fabric. Spirit varnish must be used, as linseed or any form of oil varnish will penetrate the wood and render it unfit for glueing should repairs become necessary. Spirit varnish can easily be removed by means of a punch, when, and if, necessary.

Metal work may likewise be treated with spirit varnish, but it is better to give it a coating with a lacquer which will prevent it from rusting.

When applying glue to any section made of ash, it is advisable to roughen the otherwise very smooth surface of the wood with a toothed plane or rasping file.

Curved pieces of wood are required in the construction of certain parts of the machine, and bent wood

suitable for this purpose can be purchased. Another method is to take a suitable number of thin strips of wood and to glue and fashion them to the required shape by means of a template and clamps (see fig. 33). Strips of ply wood may also be used. If these tend to snap on being bent they should be brushed over with water to render them more pliable.

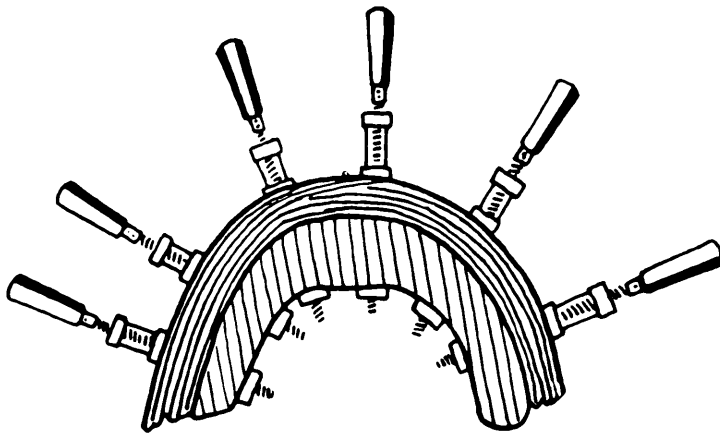

FIG. 33.

Fashioning glued strips of wood by means of a template and clamps.

A leading edge can be covered with three ply without the use of nails, if a number of strips of wood are laid along it, and the whole securely lashed to the frame by means of a wet clothes line. As the line dries it will contract and thus the necessary compression required for the glueing process will be exerted (see fig. 34).

An adjustable compass plane is an indispensable tool, as it can be adjusted to plane either the inside or the outside of any curved surface.

If an electric boring tool is used, it should be of a pattern similar to a dentist's drill, on which the drill is attached to the machine by means of flexible tubing.

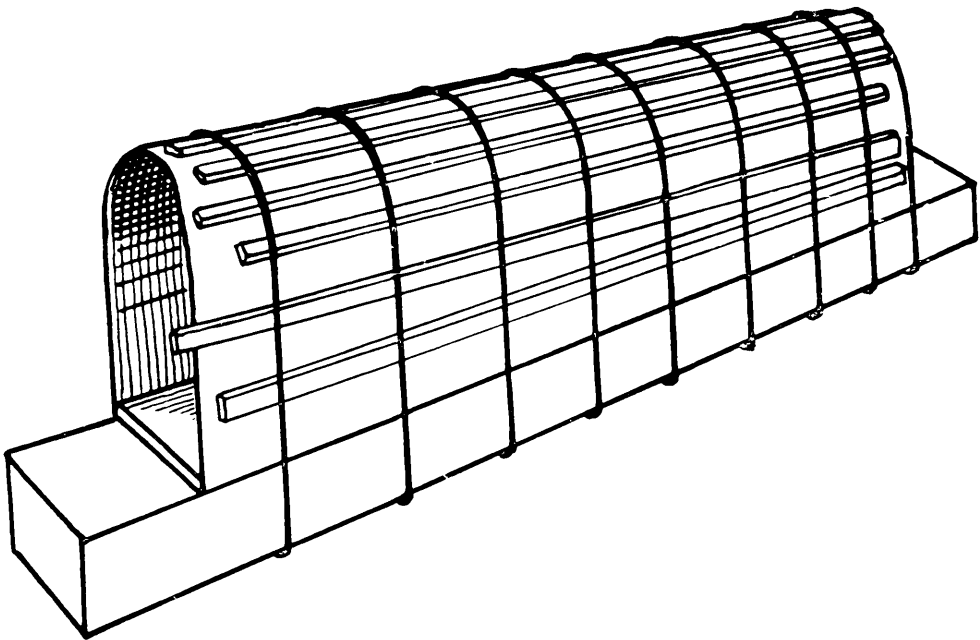

FIG. 34.

Glueing an edge by means of strips of wood and a clothes-line.

This enables the workman to reach certain awkward spots impossible with an ordinary machine. All boring, even in wood, should be carried out with the aid of a metal drill which does not tear the material and gives, at the same time, a more uniform

bore. In exceptional circumstances, when a hole must be bored and the spot cannot be reached with the machine after that section of the plane has been assembled, holes may be burnt by means of red-hot wire, care being taken to use wire that is considerably less in diameter than the required hole. This method destroys the grain of the wood and should therefore be adopted only as a last resource.

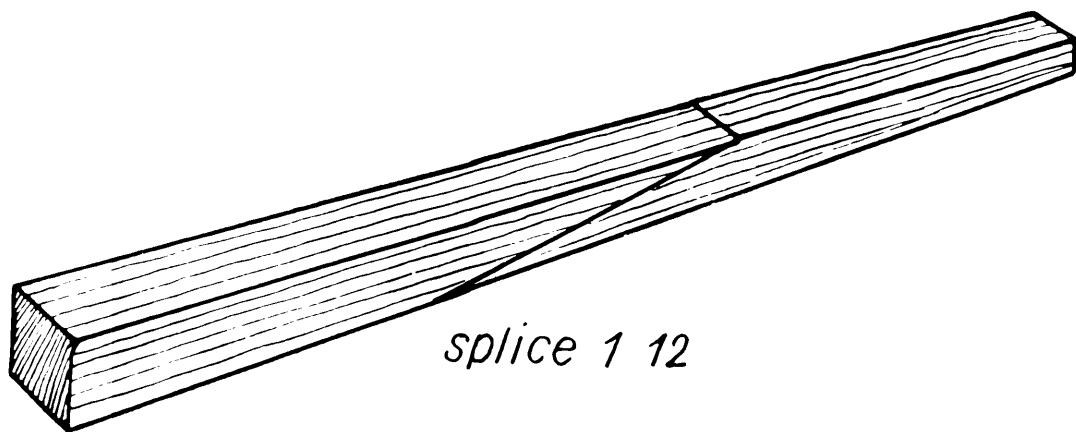

FIG. 35.

Care must be taken when mending fractures, particularly on spars, that the joint is well executed and strengthened in such a way that it will not give under the weight of the hold-fast during the drying process. The fabric cannot be stretched taut on a wing with a bent spar, and such a spar will break again under the slightest strain. All joins must be executed in a ratio of 1 : 12, that is to say, the glued section must be at least twelve times the length

of the diameter of the fractured section. When a stay, in the form of a thin piece of wood is glued to a spar to mend a fracture, extreme care must be taken to plane off the stay at each end, to obtain a gradual transition from the stronger to the older and weaker material, and to avoid ridges which would lead to a further fracture. The same applies to filling blocks (see fig. 36).

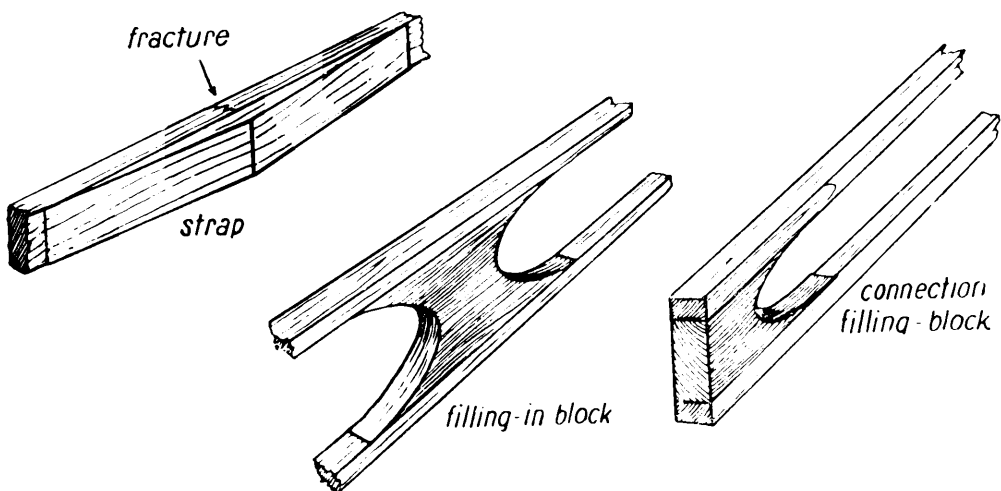

FIG. 36.
Avoid notches.

When using a bordering tool for metal work, care must be taken to bend the metal cautiously to the exact angle indicated on the plan. If bent too sharply, the metal will crack and the cracks will develop into breaks later on. Fitted blocks of softer metal, such as aluminium or copper alloy, are placed between the jaws of the vice and gently

bent to a suitable angle. On no account must the metal be heated by means of a blow-lamp, etc., as this causes it to lose its firmness. The metal work on a machine is of great importance, and money spent on it is money well spent.

The wing fabric may be of cretonne, closely-woven cotton, spun silk, tussore silk or a similar material containing little or no dressing. The fabric must be "doped" to prevent it from rotting. Cretonne may be treated with water-glass or casein, but other materials would not tighten up under this process. Hot starch may be used to preserve linen fabrics, but if either starch or casein has been used, it is advisable to give the wing an additional coating with spirit varnish, to protect it against damp. It is always better to experiment with a piece of material stretched taut over a frame, in order to test whether the "dope" actually does serve to tighten it up. It should be mentioned in passing, that fabric treated with water-glass may take several days to tighten up.

If the machine is liable to frequent exposure to damp, it is advisable to give all wires and ropes a coating with a suitable preservative. It goes without

saying, that under such conditions, all bearings and guide-pulleys must be carefully greased.

All bolts must be rivetted over to prevent the nuts from slipping off. Large washers should be used to protect the wood from destruction by the nut (see fig. 37). Fir wood is soft and care must therefore be taken when screwing up nuts not to injure the wood.

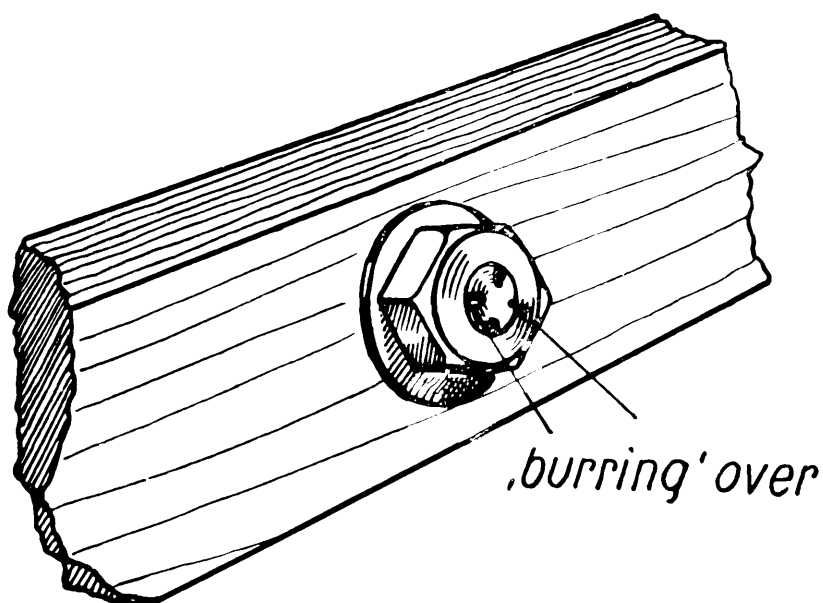

FIG. 37.

When pine wood is used, only the outer section of the tree trunk can be utilized, as the centre is generally

very resinous and consequently heavy and difficult to glue.

Small knots may be ignored if they occur in one of the thicker spars, provided they do not appear in the grain of the upper or lower surface. The wood must be straight-grown; that is to say, the grain must not run obliquely across the spar, as fractures are liable to occur if this is the case.

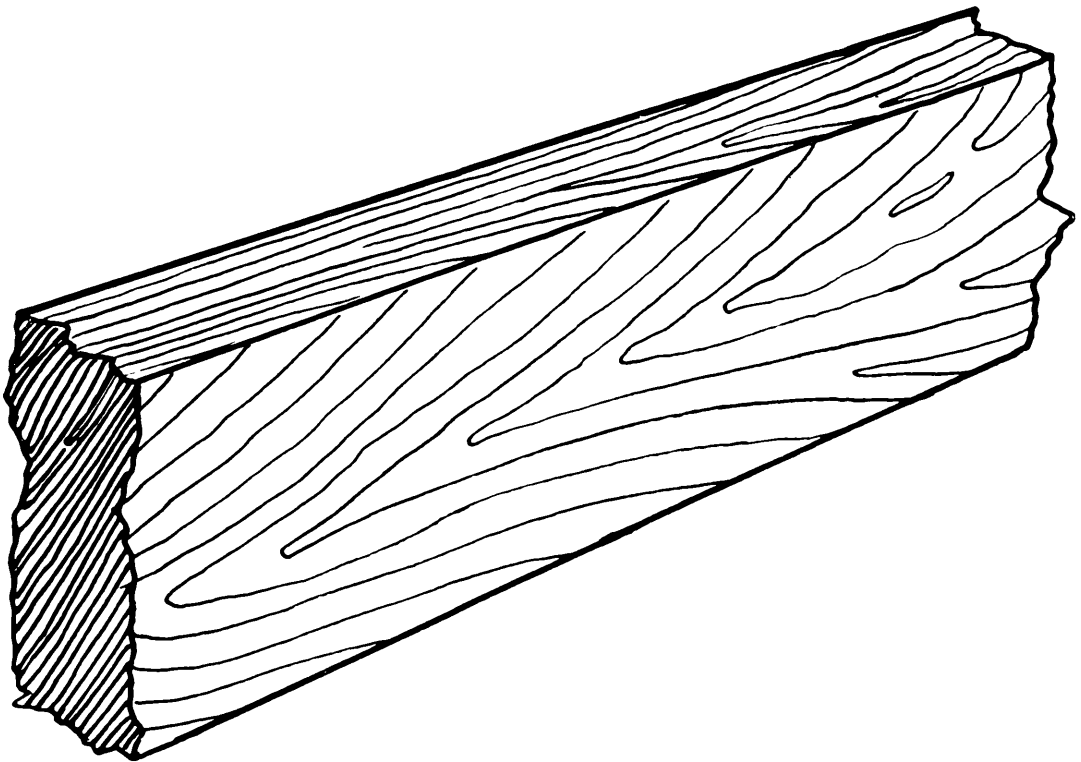

FIG. 38.
Wavy-grown timber.

The wood must be dry and well seasoned. Damp wood warps and consequently cracks would appear

wherever glue had been applied. If the wood has been damp and has, as a result, slipped under the saw and not cut straight, it is still possible to utilize it for struts, etc., by glueing two thicknesses of the wood together (fig. 39). Thus the strut as a whole is straight and the weakness or fault in one piece of wood serves to counteract the fault in the other.

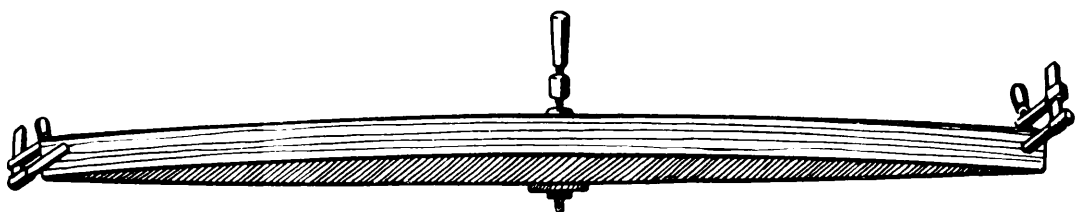

FIG. 39.

The curved strips of wood are glued together and held in place by means of a press.

The body and wing sections are constructed with diagonal supports to give them torsion rigidity, and great care must be exercised to prevent them from being built askew. To prevent mistakes these sections are constructed on stocks which have been tested by means of a water-level. Figure 40 serves to make this process clear.

It must be borne in mind that a right and a left wing are necessary. It frequently happens that the

builder discovers to his dismay that he has made two right or two left wings.

The method common among carpenters and locksmiths, of scoring a measurement on wood with a tracing-point, is to be condemned in aeroplane construction, as it tends to destroy the surface grain of the wood. All measurements should be marked off with a lead pencil.

In winter, the glueing process must be performed in heated rooms or workshops, as glue does not hold if applied at a low temperature.

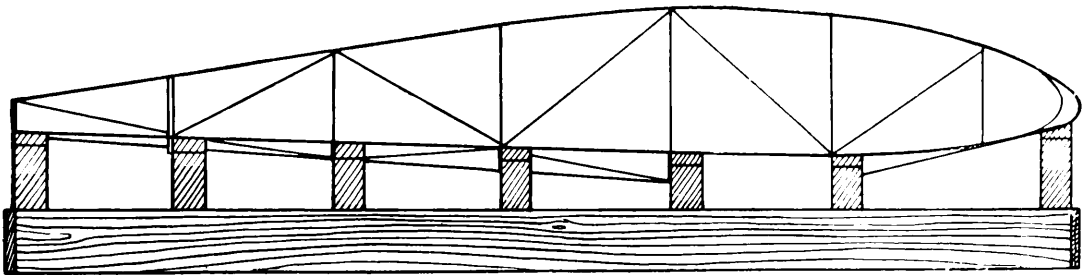

FIG. 40.
Body-work on stocks.

Glued sections which appear insecure, especially where fractures have been repaired, may be strengthened by means of a bandage. A strip of material saturated with size is bound very tightly, puttee-fashion, round the section in question. Any part

which has been glued should remain at least four hours (longer, if the temperature is rather cool) in the vice or clamps. Sections which have to be glued together must be carefully fitted ; it is of no avail to attempt to force them together by means of clamps, because this strains the wood so that the glued sections will crack under the slightest provocation. To fill long cracks with glue is likewise foolish. The important point is not that scamped work may not be seen, but that glued sections must hold.

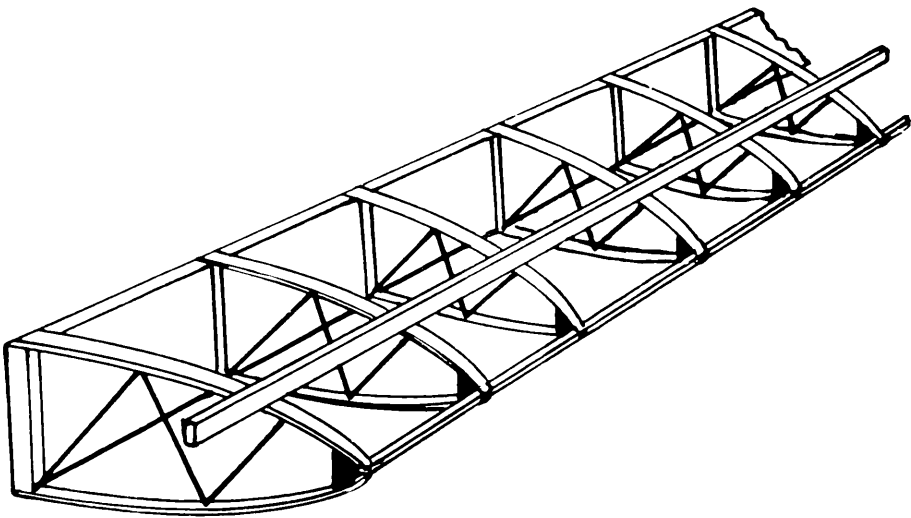

FIG. 41.

Testing ribs by means of a guide rod.

Glue exuding from a joint must not be wiped or scraped away, but allowed to dry on the wood. Ply wood may be spliced, if the sections are planed off

in the ratio of 1 : 12 as shown in figure 36; glued, and left in the clamps until dry. In this way, the two sections are joined in such a manner that the repaired section is slightly thicker than the rest.

It is advisable when working on the planking of the body work, wing edges, etc., to complete any necessary joining operations before assembling the parts, and to place the joined sections so that the join coincides with a rib.

As, particularly on tapering wings, it is important that the fabric should be stretched absolutely taut over the ribs, a guide rod is used to test whether the ribs lie level and do not either protrude or recede. If any prove faulty, they must either be planed down or a piece must be glued on (fig. 41).

CHAPTER VIII

Maintenance of a Machine

MORE attention must be paid to the condition of machines used by beginners than to any others. It goes without saying, that the first care of any airman should be to keep his machine in perfect trim, but for the beginner the condition of the machine is of the utmost importance. It is only natural that he should experience difficulty in accomplishing his short flights, and he runs a grave risk of crashing if his machine is not in perfect good order.

To true up a machine correctly is of the highest importance! If it is to fly straight, side-slipping neither to the right nor to the left, and with the correct balance, it must be properly trued up. The angle of the front spar above the rear spar should neither increase nor decrease towards the wing-tip. This may be tested by standing at some distance

from the machine and sighting under the level of the leading edge of the wing towards the trailing edge. Both wings should form the same angle with the body of the machine, so that there is not more resistance on one side than on the other (fig. 42).



FIG. 42.
Badly trued-up machine.

A dihedral angle is rarely found on machines used for training purposes. This may be tested by sighting along the surfaces of both wings from the tip of one of them. A slight dihedral angle may be ignored, but a cathedral angle must be corrected as it tends to make the machine side-slip while performing a turn (see fig. 43).

Not only the centre section of the machine, but also the ring-post or mast must form a right angle with each plane. If the tail of the fuselage lies crooked, the machine will naturally tend to turn.

Having made sure that the wings are in correct

position and that all wires are taut (no wire must hang loose, but, on the other hand, no wires must be over-taut as this would place too great a strain

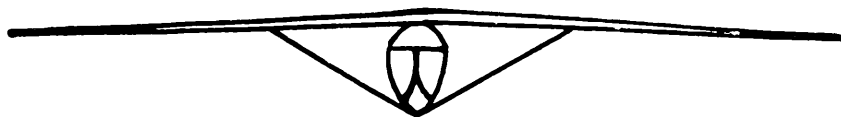

FIG. 43.
Kathedral angle.

on certain parts of the machine), the airman turns his attention to the rudders. He first brings the control lever to normal position and the rudder bar likewise. If any rudder should then be deflected, the wire pulleys must be adjusted so as to correct the fault (fig. 44).

Before each flight the airman should look over his machine, see that it is properly trued up and that no wires have worked slack, test the controls and especially the pulleys, by working the control-lever and rudder bar while carefully observing whether their operation has the desired effect on the ailerons and rudder. He must also test whether any tension shackles have worked loose ; these must be given

four or five turns to render them reliable. All bolts should be tested and the wire and cable connections inspected. Loose or missing nuts should be looked

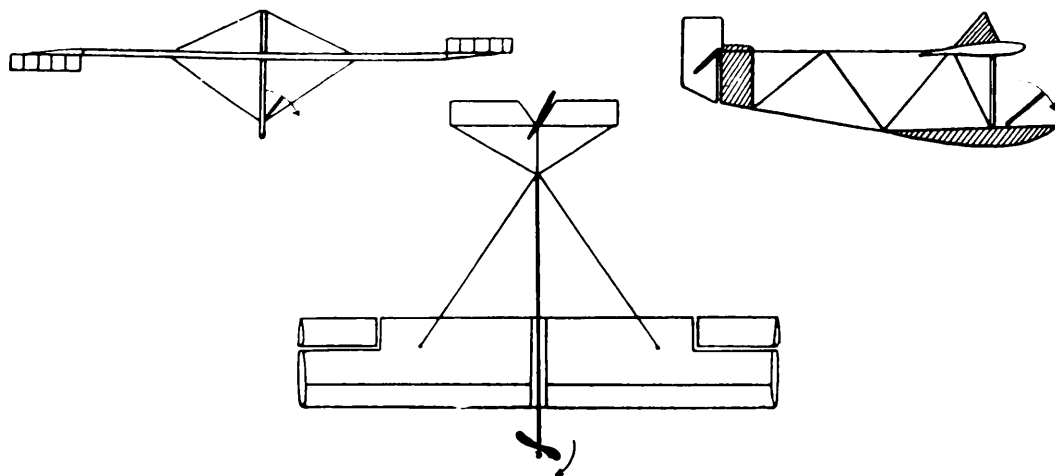

FIG. 44.
Correct steering connection.

for. The airman should always test whether the wing diagonals are firm. This may be done by trying to force the leading and trailing edges towards each other. A wing that has no torsion rigidity is extremely dangerous!

The machine should be overhauled after a clumsy landing, in case cracks or bulges have occurred. This can be tested by exerting pressure on the end of a spar and observing whether it remains in position or tends to sag. The ply-wood covering of the

wing edge is liable to break easily and must be inspected. Under no circumstances should a flight be undertaken if the spars are even slightly damaged though they may appear to hold.

If the machine has become wet, fabric which has not been rendered weather-proof by doping must be tested by blowing through it. Fabric which is not taut and wind-proof renders correct flying impossible and causes the machine to drop. A machine in a wet condition immediately becomes tail-heavy, as the rudder surfaces gather moisture

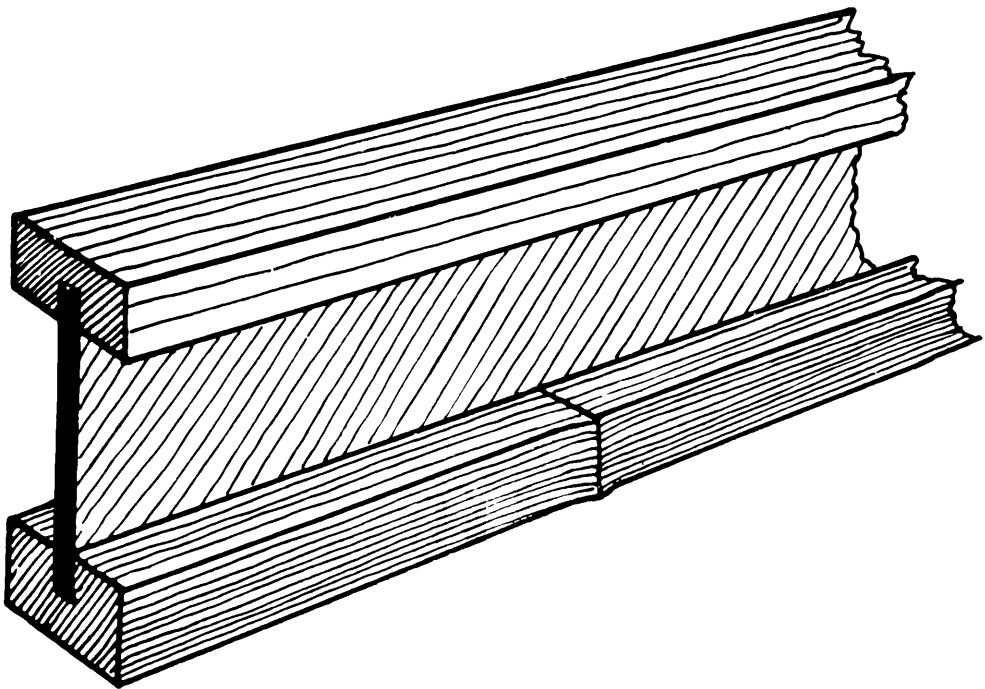

FIG. 45.

and consequently become heavier, whereas there is nothing at the nose of the machine which could increase in weight through damp.

The airman must conscientiously overhaul his machine after exposure to wet weather, to satisfy himself that all the glued sections have held and that no joins have been loosened by the damp. However careful the overhauling, the first flight each day and the first flight after repairs must be undertaken by the instructor, as he can re-test the machine in flight and discover whether it side-slips or tends to bear to one side.

The following sketches are intended to illustrate other important points.

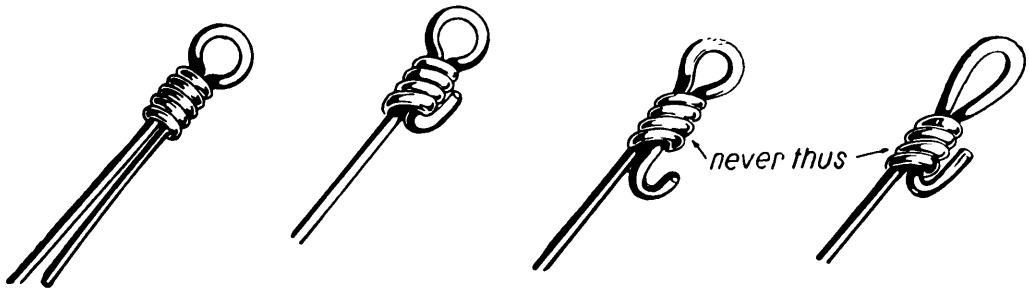
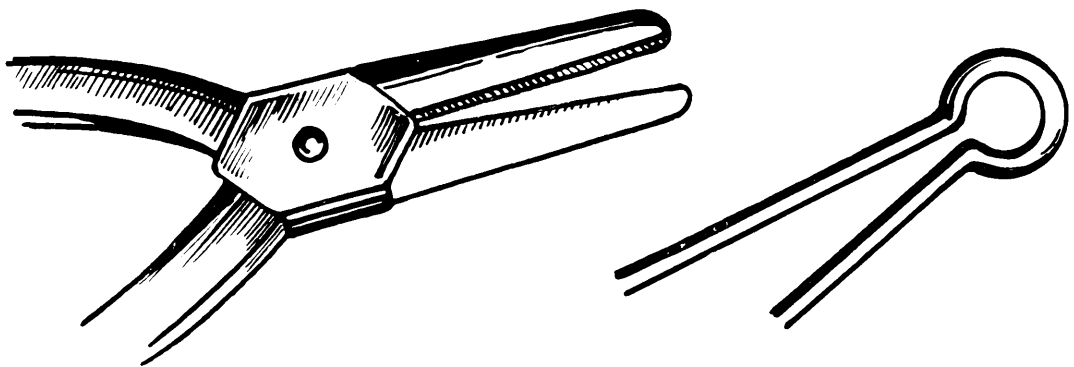

FIG. 46.

The ferrule is pushed up to the eye, when the short end is bent back to lock it.



FIGS. 47 AND 47A.

How to make loops in wire. Wire bent thus with round-nosed pliers.

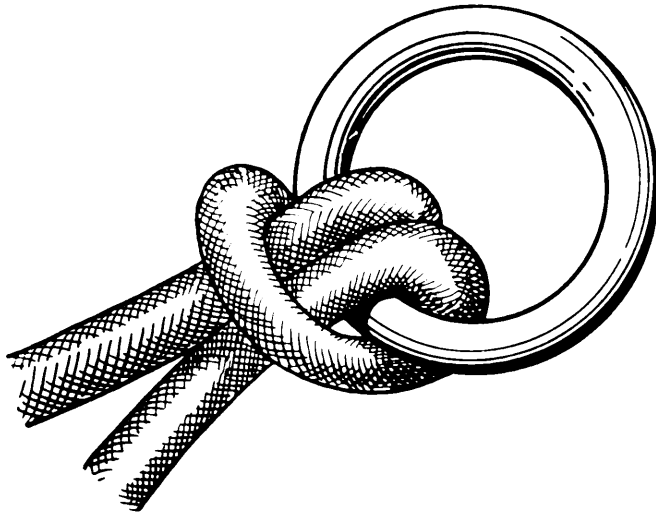

FIG. 48

The ring on the starting-rope should be of
electron, as this is less dangerous for the
starting-crew.

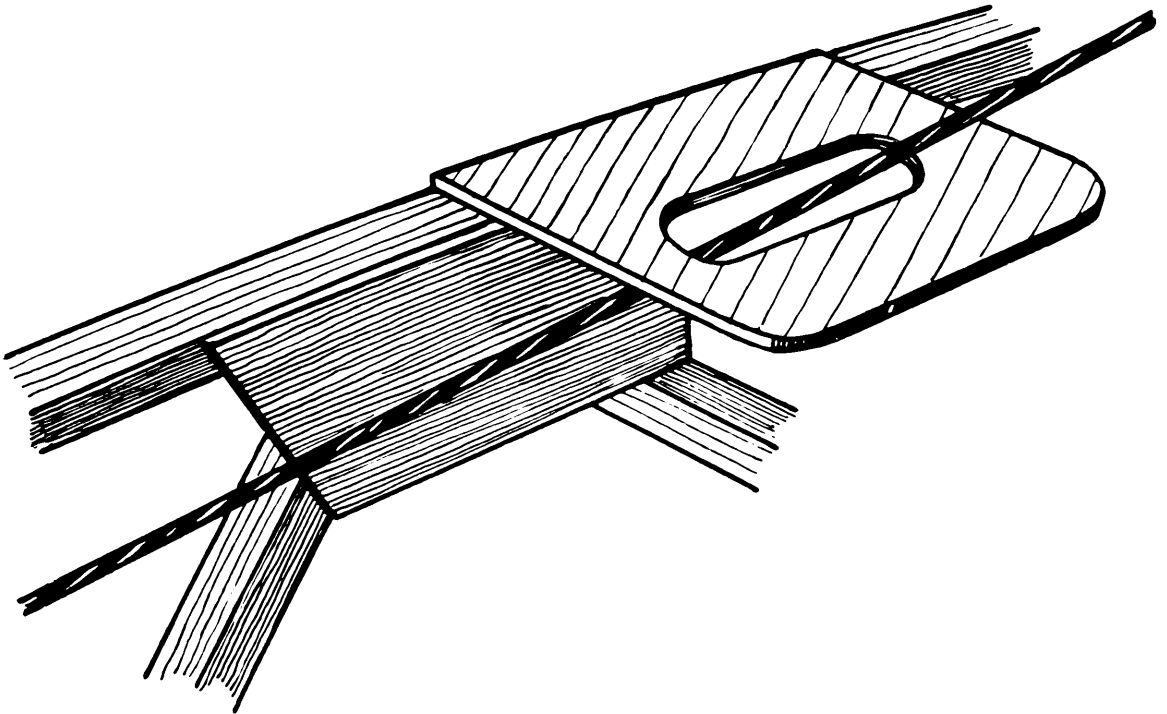

FIG. 49.

A piece of ply-wood is glued to the rib, at the point at which the
cable passes through the wing-fabric, thus preventing the slot from
becoming torn.

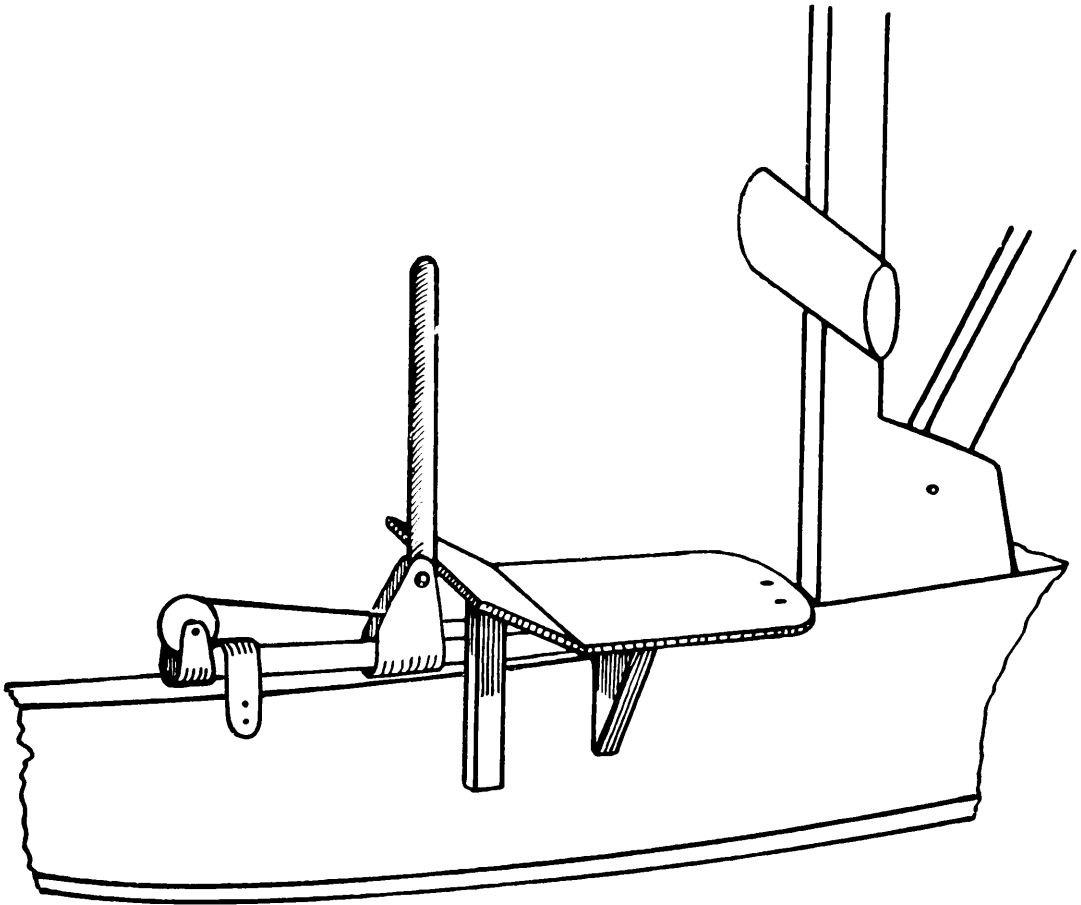

FIG. 50.
Satisfactory arrangement of pilot's seat, preventing injury by control lever.

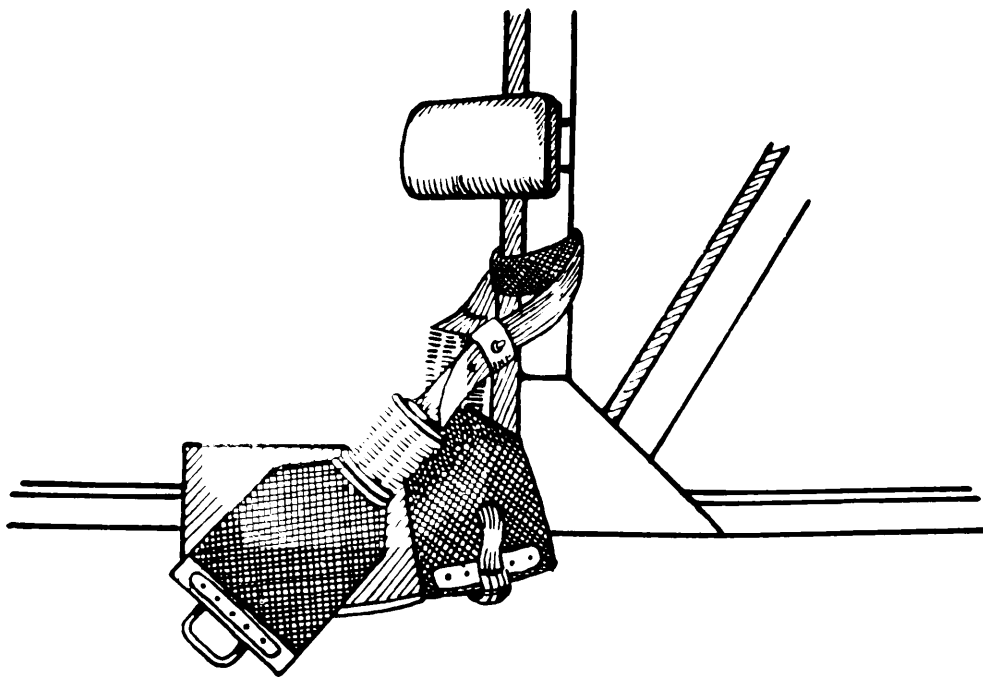
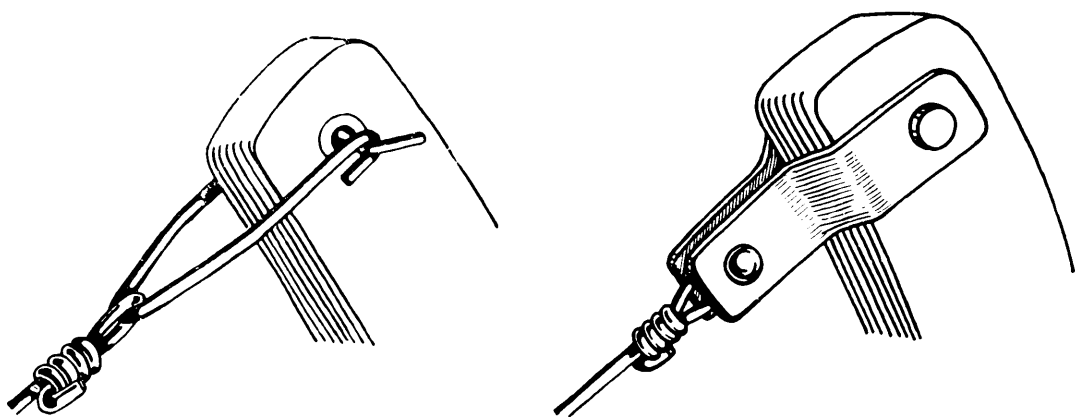

FIG. 51.

Never omit to use a broad, well-sprung safety strap.



FIGS. 52 AND 53.

(52) Wire-clasp connection. (53) Bolted connection.

If the connection has to be opened very frequently, the second method is preferable, as the wire clasp would be liable to snap.

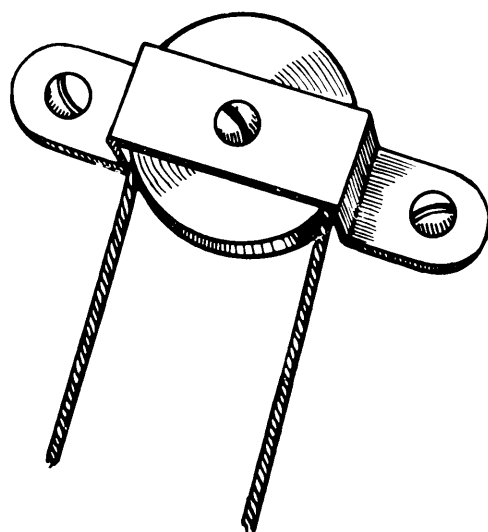

FIG. 54.

Method of keeping pulley-rope in place.

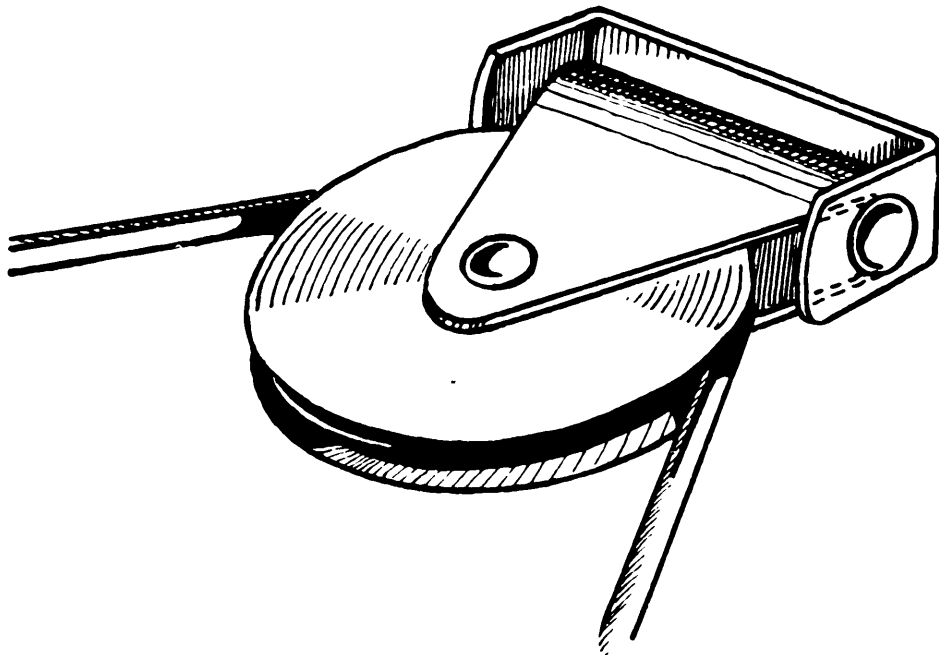

FIG. 55.

Oscillating pulley suspension, which is self-adjusting to take the strain.

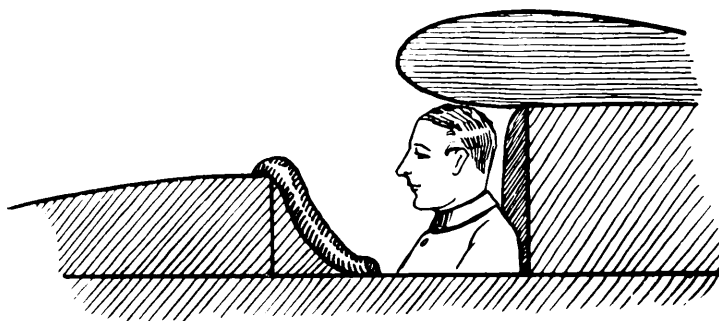

FIG. 56.

The edges of the cockpit should be well padded.

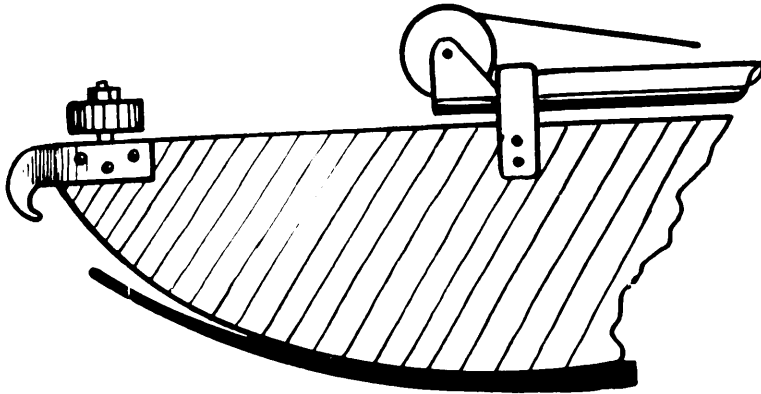

FIG. 57.

Care must be taken to see that the runner beneath the starting-hook is not slack, as in the illustration. Otherwise the rope will remain caught on it.

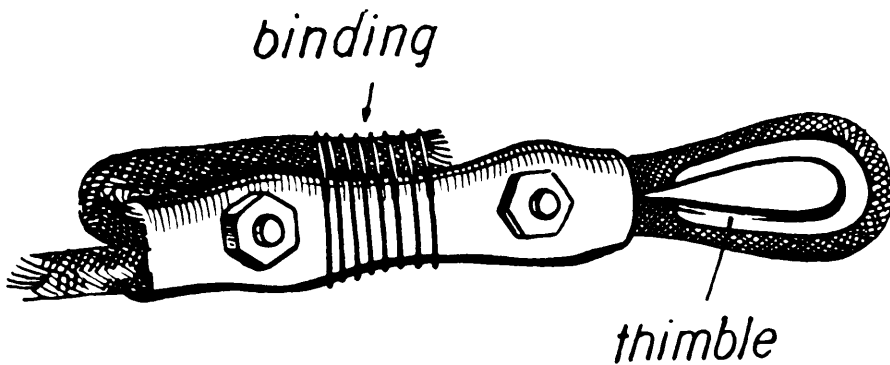

FIG. 58.

If cable clamps are used instead of splicing, the cable end must be secured with binding wire. A heart-shaped thimble must always be placed within the loop.

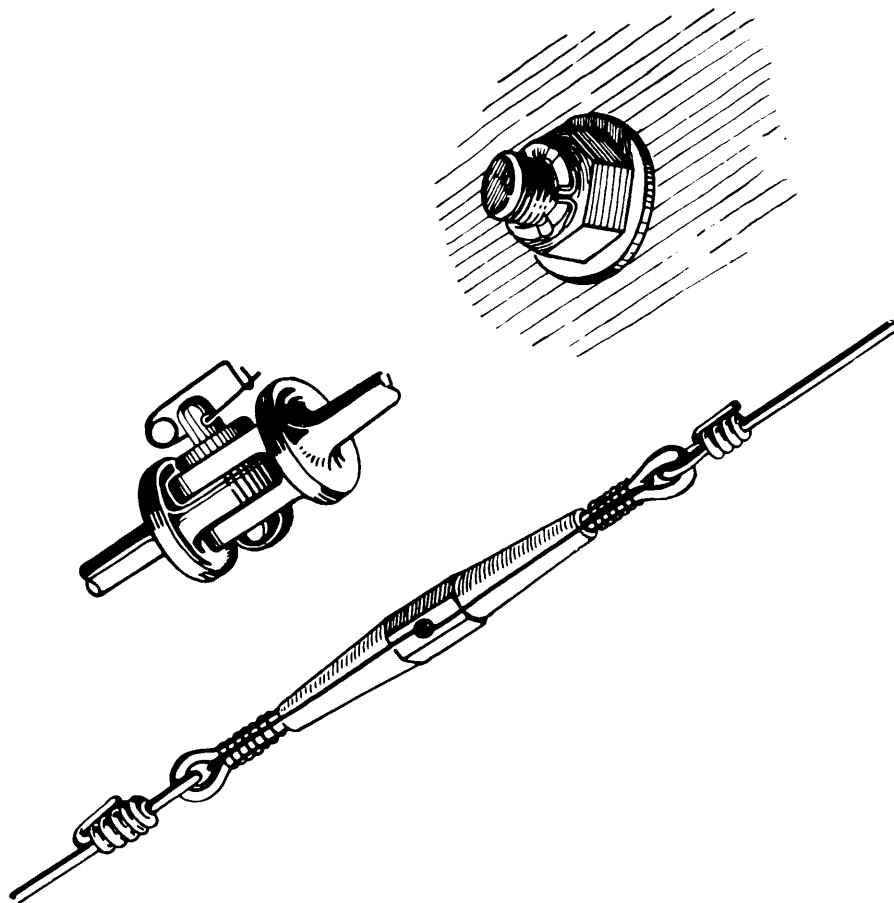

FIG. 59.

Fastenings. Turn buckle with double-threaded wire.
 Eye-bolt and shaft-bolt with key-bolt and safety-pin.
 Castellated nut with split pin.

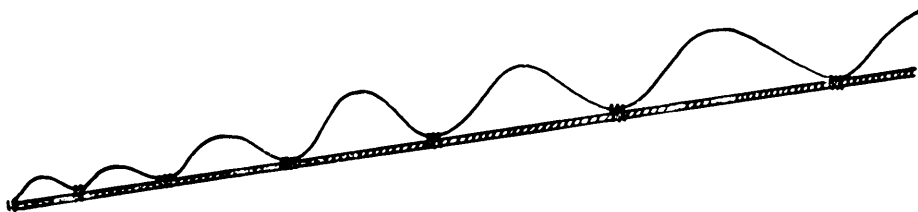

FIG. 60.

The starting-rope may be protected by means of a clothes-line
 double its length.

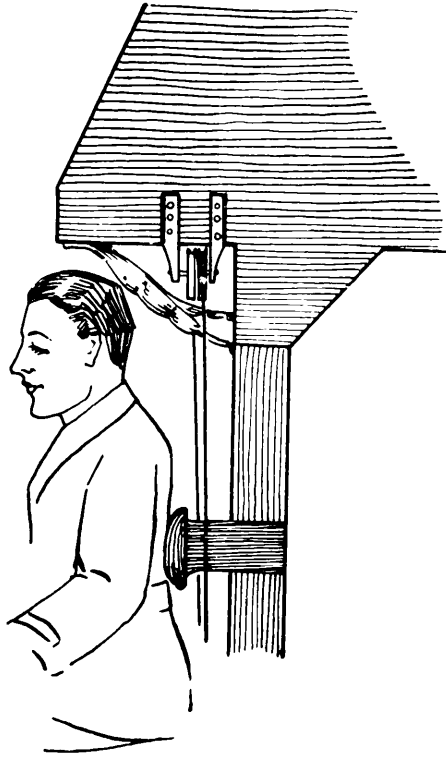

FIG. 61.

The back-rest should be well padded and a protective pad fixed behind the airman's head.

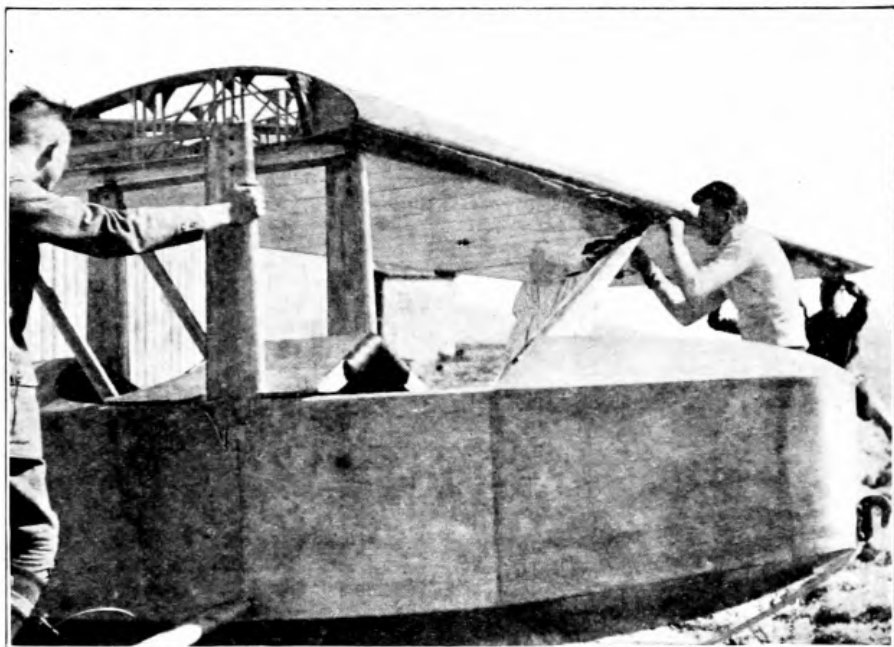

FIG. 62.
Assembling the parts.

CHAPTER IX

Training Methods

SELF-TUITION is the oldest and customary method of training for motorless flying.

Before his first flight in a machine, the pupil must familiarise himself with the details of the mechanism and the manipulation of the controls. His best plan is to sit in the pilot's seat of a stationary machine, work the controls and imagine that the machine actually obeys every separate action on his part. He must complete each movement as slowly as if the machine were really in flight. It is important to learn to pause when the machine is in correct position. Once he has acquired the "feel" of the controls and realizes that the machine must obey every movement of the control lever, it is unlikely that he will make many mistakes in its manipulation. During his first flights the pupil

should be allowed to perform the control movements with his whole body as the balancing reflex quickly teaches him to perform these movements correctly.

The use of the rudder presents considerable difficulty as it is contrary to the usual means of steering, in an automobile, for instance. In this case practice makes perfect. A good method for the beginner is to sit on a chair, on the ground, or, better still, in the machine itself and to practise the foot movements, remembering that the machine will always turn towards that side on which the rudder bar or pedal is thrust out. The pupil should be given to understand clearly that when he becomes more proficient, he will have to use the directional rudder in conjunction with the ailerons when performing turns and that his knees must then be quite wide apart. For instance, when he used the right aileron his right leg would be in the way if the directional rudder were not simultaneously thrust out to the right.

The pupil must also be made to realize that steering is not essential in flying. One may, in fact, keep the control lever and the rudder bar steady, as long as the machine is in normal position. As soon, however, as it ceases to be so, the corrective steer-

ing movement must be performed. The sooner the correction is made, the less disturbed the flight.

It is hardly necessary to add that a beginner should be permitted to perform his first flights only if weather conditions are favourable, so that his task is merely to keep the controls in position.

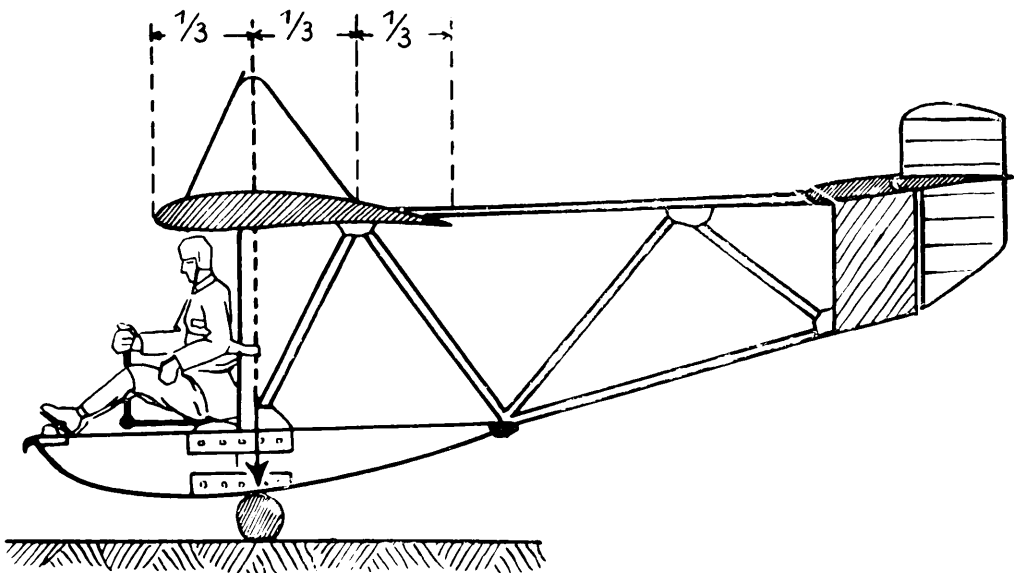

FIG. 63

Point of balance. (Approximately one-third of the wing-chord measured from the leading edge— exactly 35 per cent.)

Before the start, the instructor must see that the pupil has his control lever at normal. The start in a gliding machine is very different from

that in an engine-driven aeroplane. There being no under-carriage the gliding machine stands on the ground, in what is practically normal position and is given its initial impetus in the air by the starting crew. Thus it is not necessary, as in the motor-driven plane, to push forward the control lever at the start and then to ease it back when the necessary flying speed has been attained.

In a gliding plane the pilot generally sits in front of the centre of gravity of the machine, thus counterbalancing to a certain extent the weight of the body and tail. Most machines are constructed to carry a weight of seventy-five kilograms. If the pilot is lighter the machine will be tail-heavy; if he is heavier it becomes nose-heavy. To correct faulty balance it is necessary for the light-weight rider to exercise a slight forward pressure on the control lever, whereas the heavier man has to pull it backward. It is most satisfactory, in the case of the lighter pilot to fix a balancing weight in position near the starting-cable hook, and in the case of his heavier companion near the tail of the machine. The machine plus its occupant and the balancing weight must then be carefully trued up in the following manner (see fig. 63). At the point indicated in the figure, at which the centre of gravity lies (this

is generally reckoned by means of a plumb-line from a point at one-third the distance of the wing-chord measured from its leading edge), a beam is placed underneath the runners. The machine should balance exactly on this beam. If it is impossible to obtain an exact balance, it is preferable to have the machine nose-heavy rather than tail-heavy. Tail heaviness is always a source of danger, whereas extra weight at the nose may prove an advantage.

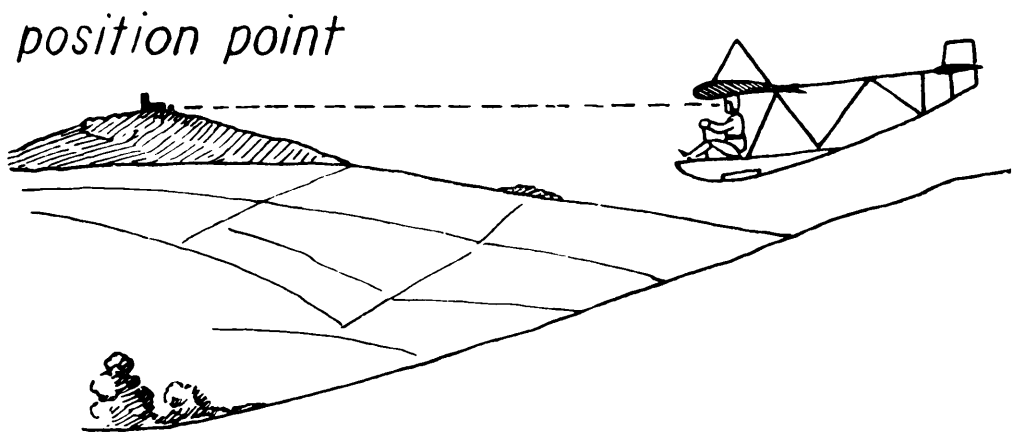

FIG. 64.

The position point is chosen at eye level.

The trueing up of the machine must take place either in the hangar or in some spot completely protected from the wind, as the force of the wind

against the planes would lead to an entirely wrong result.

It should be duly impressed upon the beginner that he must on no account look down at the ground beneath him or at his control lever. It is only natural that a beginner who has not as yet acquired the "flying sense" should look for landmarks by which he can judge whether or no his plane is flying correctly. This he cannot, however, discover by glancing at the earth beneath or at his controls. As a matter of fact, the controls may be at normal when the machine is side-slipping badly. In order to have a landmark by which he can judge his direction and altitude and whether he is flying laterally level, he chooses a so-called "position point" on the horizon, or in hilly country, some distant point on a level with his eyes. (see figs. 64, 65).

As every glance at the machine is dangerous for the beginner on his first flight, there should be no instruments on board his plane, and he should fly simply according to his position-point, that is to say, the horizon. The beginner must bear in mind that the line of the horizon should lie dead in his line of sight and that, providing he maintains a correct sitting position, this line will dip when he pulls the

control lever backwards and will rise when he pushes it forward.

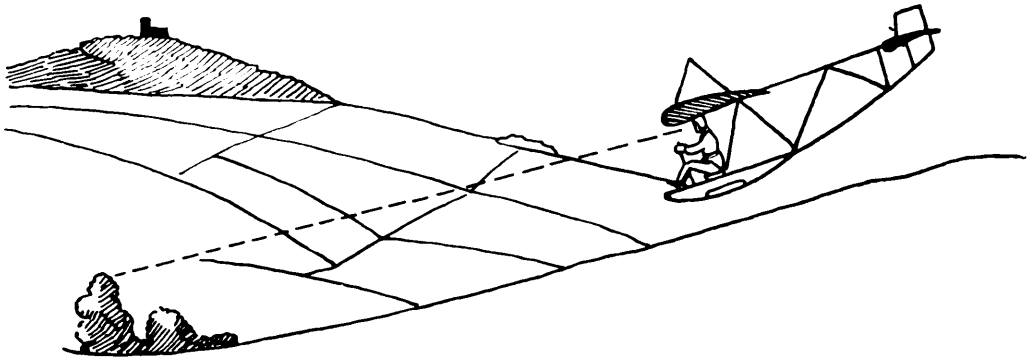

FIG. 65.

(If the position point chosen is too low, the machine will descend.)

It is possible, by making use of such landmarks, to fly as correctly as with the aid of an infallible instrument.

By observing the horizon line with which his machine must be kept level, the pupil can judge whether his plane is side-slipping. Similarly, he knows that he must be deviating from his course if his position point lies too far to his right or too far to his left (see fig. 66).

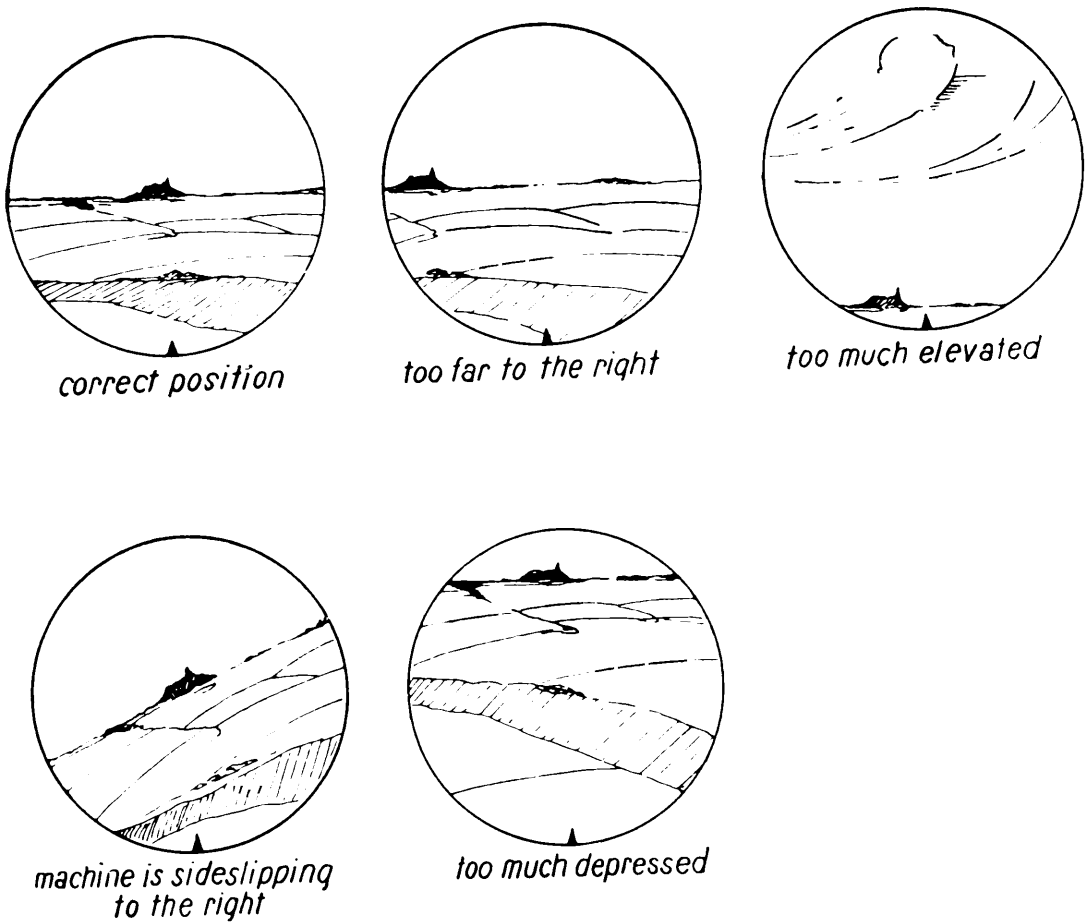

FIG. 66.

(Lie of horizon and position point. The nose of the machine is visible at the foot of the sketch.)

The beginner must pay great attention to the manipulation of the rudder, which is strange and difficult. Most accidents are caused by faulty rudder manipulation.

The pupil must remember that an engineless glider can neither fly horizontally nor ascend, but must remain in a downward gliding position if it is not to lose speed and consequently, its flying capacity. Flight is speed! Every machine requires a definite speed to enable it to fly, this speed varying according to its build and weight. It is therefore possible to fly with the aid of a speed indicator. As every instrument is, however, liable to get out of order, and as a pupil who always depends on instruments can never acquire the true "flying sense," it is better for him, as a beginner, to judge the correctness of his flight by position rather than by speed, since it follows as a matter of course, that a machine flying in correct position will attain the required speed.

The pupil must also learn to use his sense of hearing. If he has trimmed his machine correctly with the horizon line, he will hear a peculiar sound caused by the wind against the framework of the machine. As his speed increases this sound becomes

louder and as it decreases the sound becomes deeper and gentler. Thus the singing of the wind may be a guide to the airman.

On longer flights the rider can glance at the outline of the wing, using it as a guide to correct his position, if necessary. The wind is admittedly invisible, but as the airman can see stretches of country, he can gauge the horizontal, and as the direction of the wind is generally assumed to be horizontal to the plane, he can correct the angle of his wing and consequently, his position. The practice of glancing along the wing serves to instil confidence into more advanced pupils. They gradually realize that they may move their bodies slightly and that they do not need to be too painfully on the alert for trouble. The instructor should, indeed, impress upon the beginner that he ought not to sit in the machine with every muscle taut. Unless he allows his muscles free play he cannot expect a smooth reflex action and will find that his manipulation of the controls is sudden and jerky. If he jerks the control lever clumsily backwards, it stands to reason that the machine will answer in the same undesirable fashion. Only rarely and in critical situations, when instantaneous action is necessary, should the control lever be thrust over abruptly.

A very common and extremely dangerous error is to pull the control lever too far over. It cannot, therefore, be too often reiterated that one can glide downward only, and that speed is necessary for flying.

The pupil must think out each flight beforehand, and accomplish it several times in imagination. Only he who sets about it in real earnest can make a success of flying. It is absolutely wrong to assume that flying is a frivolous pastime, the art of which can be acquired in a day.

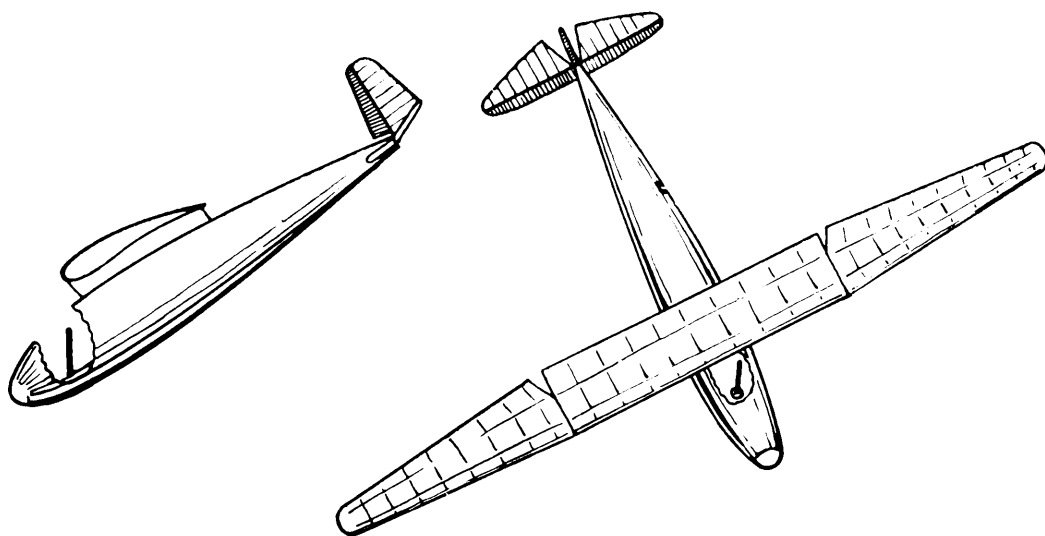

FIG. 67.
Positions of the control lever.

After a flight, the pupil must ponder each incident and make certain that he understands what he did and what he ought to have done. It is important for him not only to discover for himself what his mistakes have been, but to discuss them frankly with his instructor. If a pupil has found himself in an awkward situation without the remotest idea as to which rudder to use, he must imagine his machine once again in this position with the control lever at right angles to the earth surface. This gives him the position in which the control lever must be placed before the machine can regain normal position (see fig. 67).

Beginners are sometimes trained in machines with dual controls, so that the instructor can sit in the machine with his pupil. The instructor does the actual steering and the pupil learns in this way to manipulate the controls by following each consecutive movement.

As his confidence increases, the pupil is gradually allowed to take over the controls, until he is at length ready to undertake his first solo flight. What has already been said regarding self-tuition applies also to the first solo flights of a pupil trained on the dual control method.

In the following section, numerous situations have been sketched, in order to give a clearer impression of what an airman ought to do and what he ought not to do.

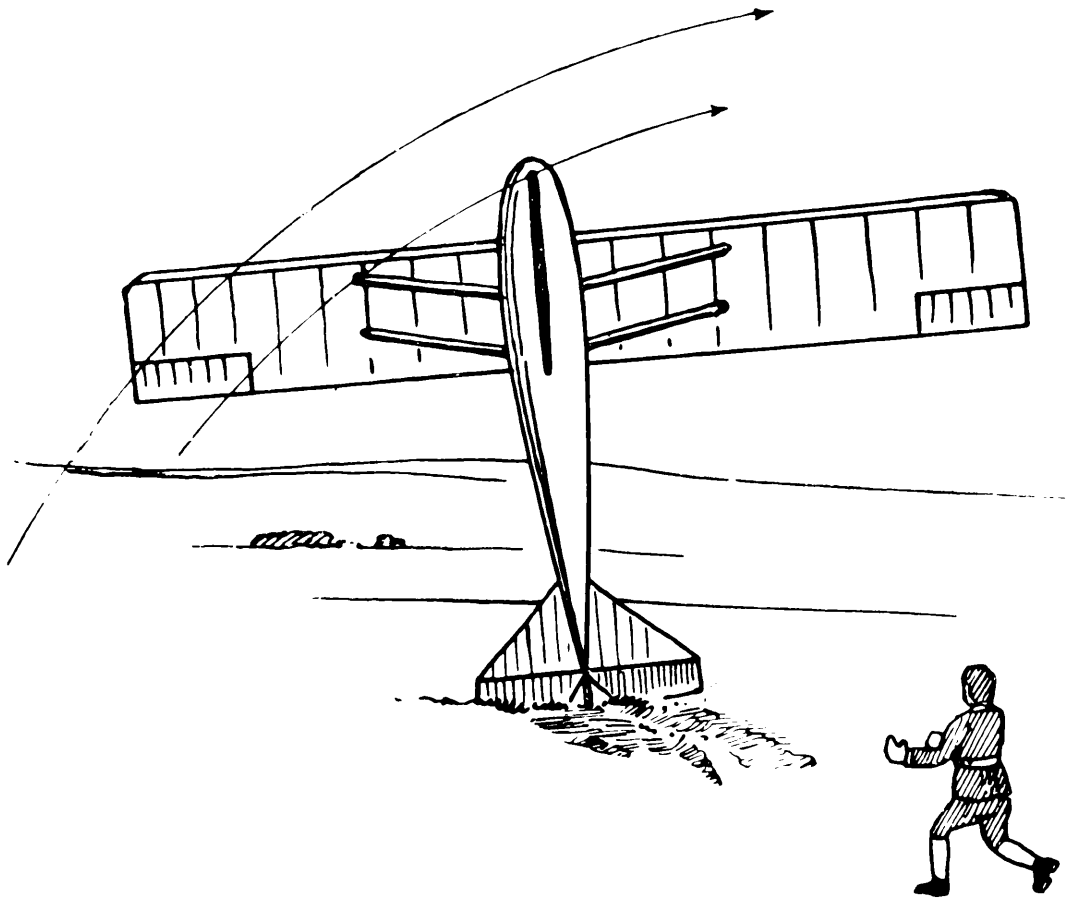

FIG. 68.

After landing, remain in the machine, otherwise it will be overturned by the wind.

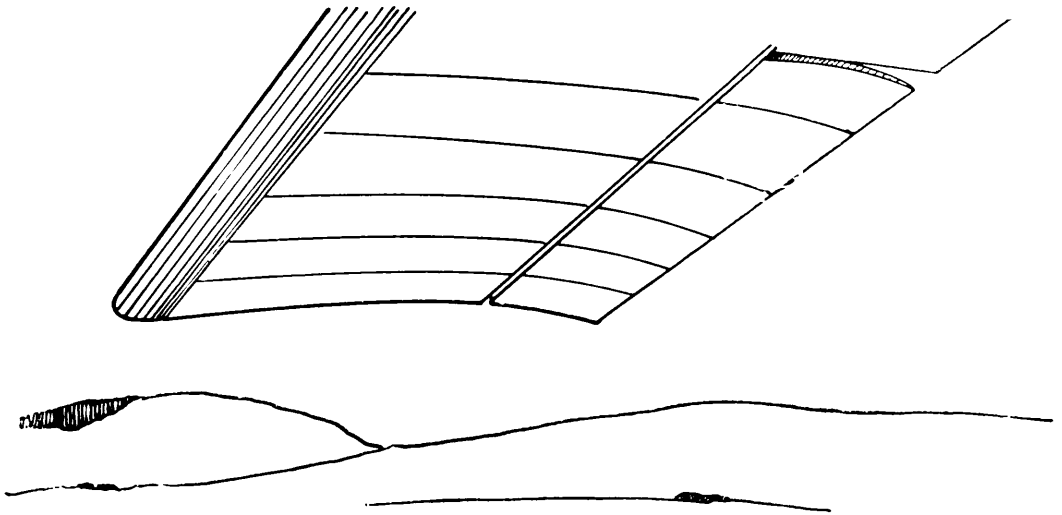

FIG. 69.

A glance sidewise along the wing shows the flying position of the machine.

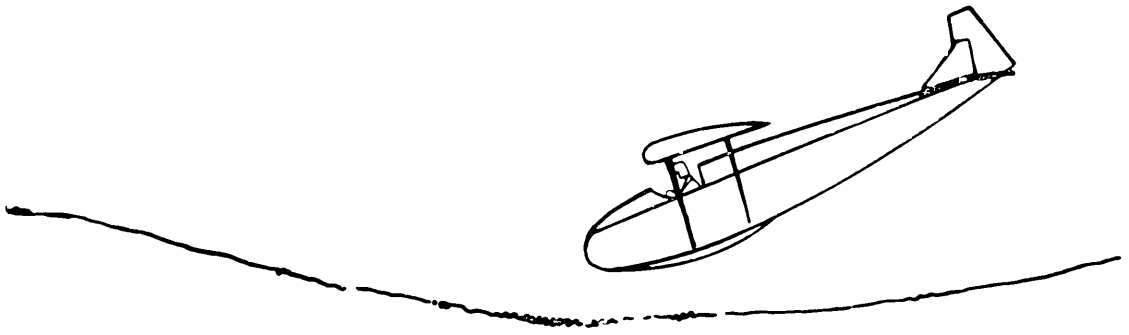

FIG. 70.

When landing on an up-gradient, bring the nose of the machine close to the ground.

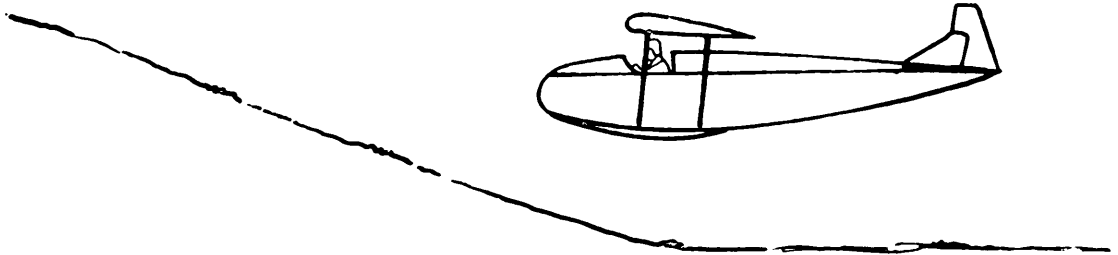

FIG. 71.

Do not attempt to fly up a slope in normal flying position or you will crash.

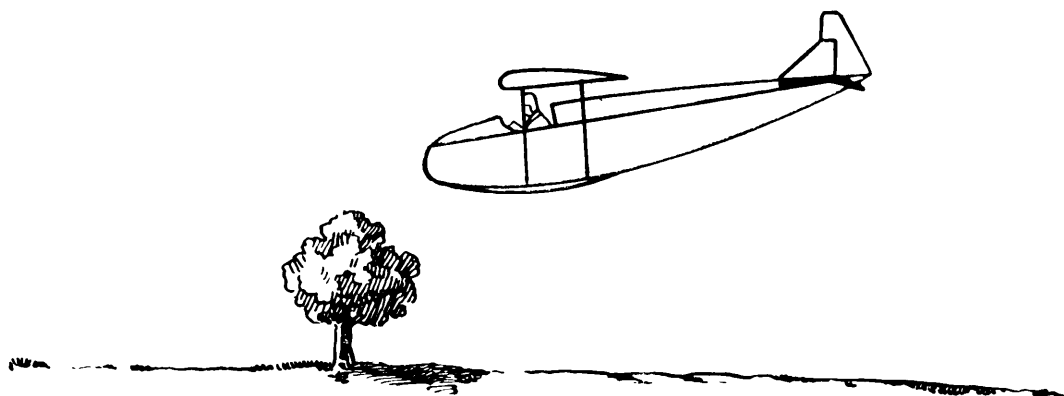

FIG. 72.

Nose the machine towards any obstacle which has to be surmounted.

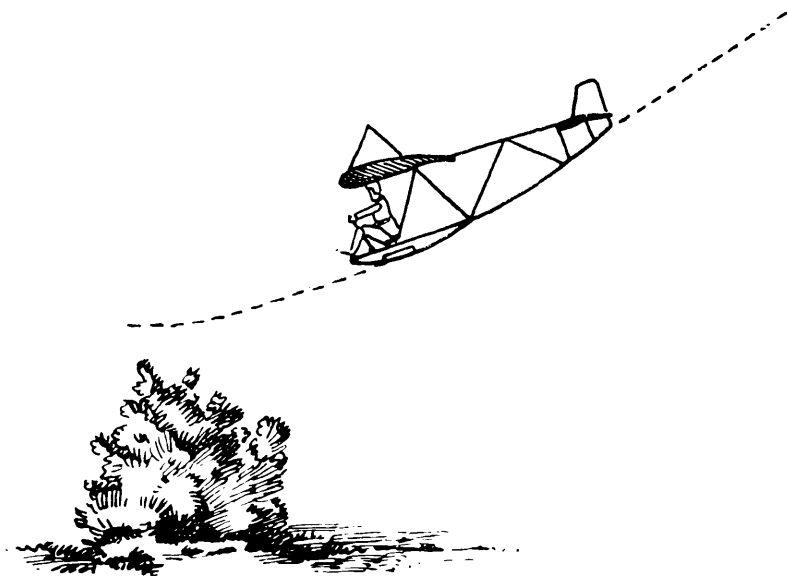

FIG. 73.

Steer directly for an obstacle and bring the machine neatly over it.

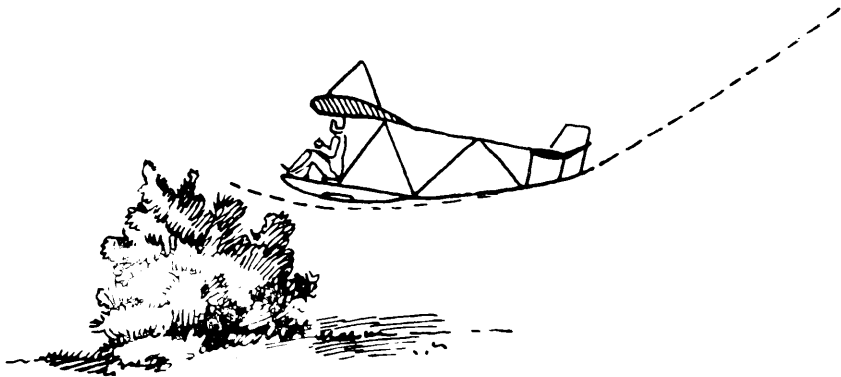

FIG. 74.

Do not pull back the control lever too early otherwise the machine will not clear the obstacle.

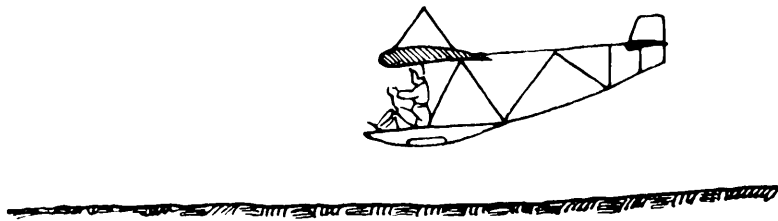

FIG. 75.

Before landing allow the machine to hover just above the surface of the ground.

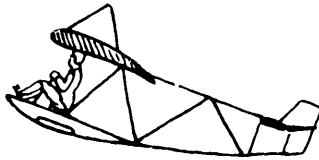

FIG. 76.

Do not pull back the control lever too suddenly, otherwise the machine will "balloon" and then crash.

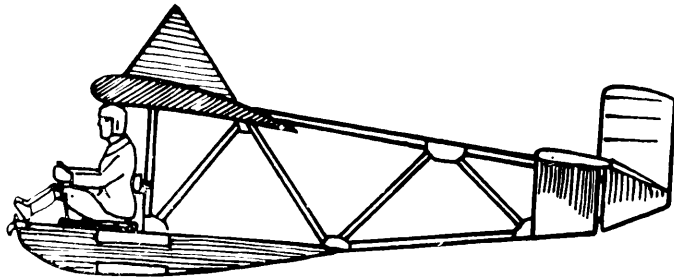

FIG. 77.

Never glance down towards the ground, otherwise you will descend.

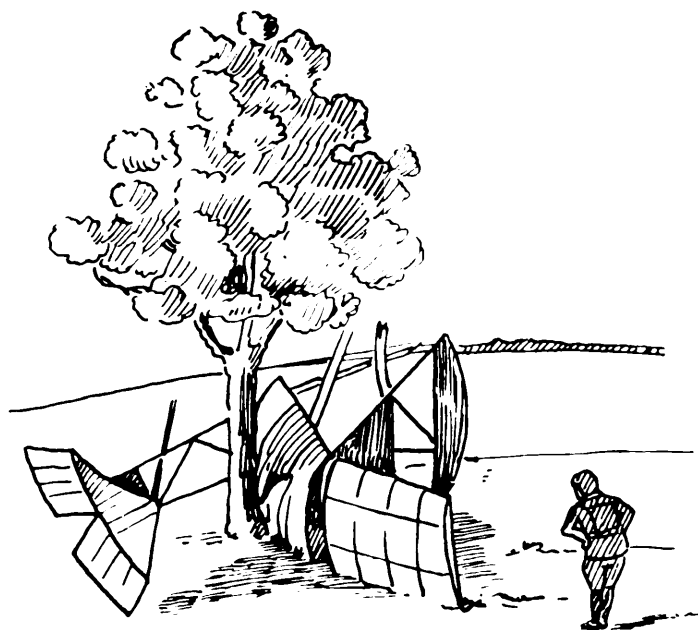

FIG. 78.
Neglect of these rules brings punishment in its train!

CHAPTER X

Instruments—Ground and on Instrument Board

CORRECT flying is essentially a matter of feeling, and for this reason the airman should use instruments only in those situations where he cannot rely absolutely on his "flying sense," and when it might prove insufficient. On the other hand, the man who lacks this flying sense must not assume that he could ever learn to fly by depending on instruments alone.

The most important among the airman's instruments is the speed indicator, and this, while indicating the speed at which the machine is travelling through the air, indicates the wind speed also.

Flight is speed. A certain speed is required to enable a machine to fly, and lack of speed may cause

disaster. It is therefore clear that a speed indicator plays a very important part. Let us suppose that the cockpit is so constructed that, while affording protection, it prevents the airman from feeling the wind speed and that he gets into mist or into darkness so dense that he cannot discern the horizon. In such a case it would be impossible for him to reckon the correct speed without the aid of an instrument. His instinctive sense of position would, under such circumstances, entirely forsake him, and it is only when he encounters fog or darkness that the airman fully appreciates how greatly he is dependent upon his eyesight.

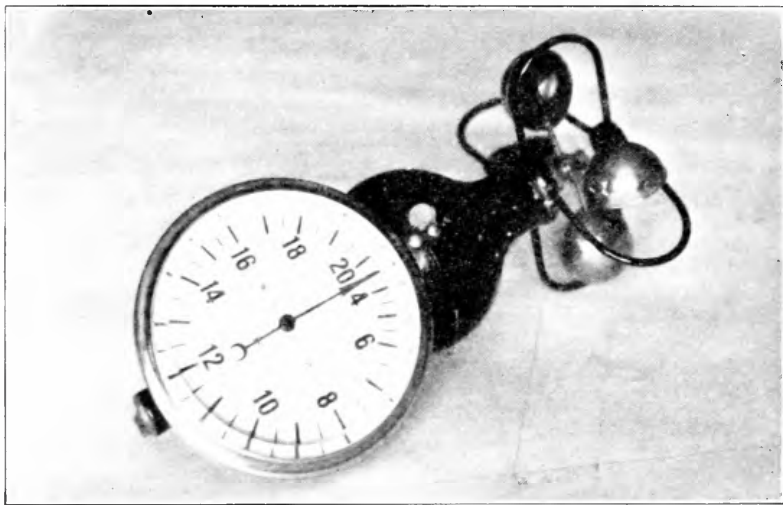

FIG. 79.

Cup Anemometer (Speed indicator).

The speed indicator is constructed with a small wheel formed of four tiny cups which is caused to revolve slowly or rapidly, according to the draught. By means of a cog-wheel mechanism this speed is transmitted to a needle which indicates it on a dial marked off in metres per second or in kilometres per hour (see fig. 79). On the ground, the airman may use this same instrument, indicating metres per second, as a wind-speed indicator. It is essential for him at his starting-point, to have exact information, not only regarding wind speed, but also as regards those fluctuations in wind speed which cause gusts.

On board the machine, a speed indicator consisting of pressure and suction tubes is generally used. One tube has its end open to the draught. The air rushing down the tube causes compression in the connecting tube, which is transmitted by means of piping to the registering instrument, fixed in a convenient position in front of the airman. Inside this instrument, there are drums similar to those in an aneroid barometer, which expand as the air pressure diminishes. A spring transmits this movement to the needle which registers it on the dial. The greater the speed of the air rushing

into the open tube, the greater the pressure in the connecting tube and the greater the speed indicated on the dial, which is marked off to register kilometres per hour.

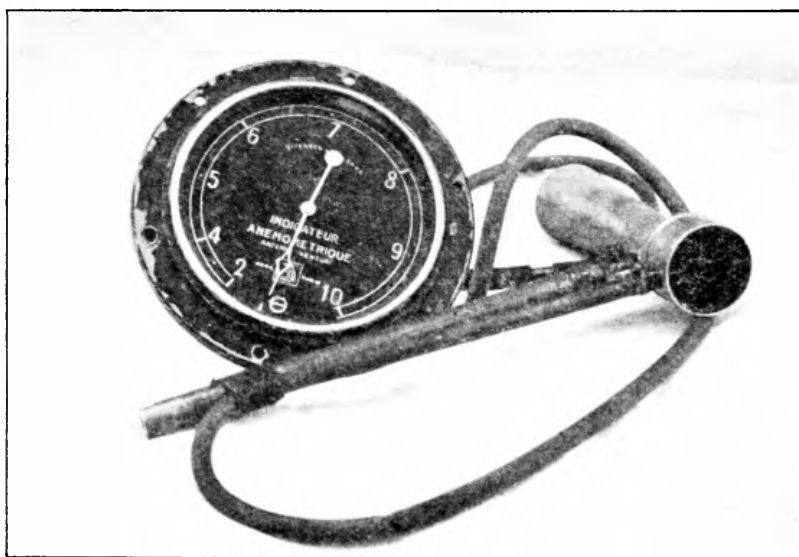

FIG. 80.

Air speed indicator, showing piping and tube.

Two home-made speed indicators for use on board are shown in the accompanying diagrams. The main difficulty experienced by an amateur attempting to make such an instrument is in gauging the scale. This scale need not, however, be absolutely correct. One may choose a suitable scale and then get an expert airman to fly the machine in which the instrument is fixed. The expert can readily

tell what the pointer registers in normal position, to what registered figure he can, without danger, make the machine ascend by manipulation of the rudders, and to what figure the pointer should fall, when the machine is made to descend. Let it be repeated that such an instrument can merely check, but never replace, the "flying sense," for instruments are liable to get out of order and thus fail to fulfil their purpose.

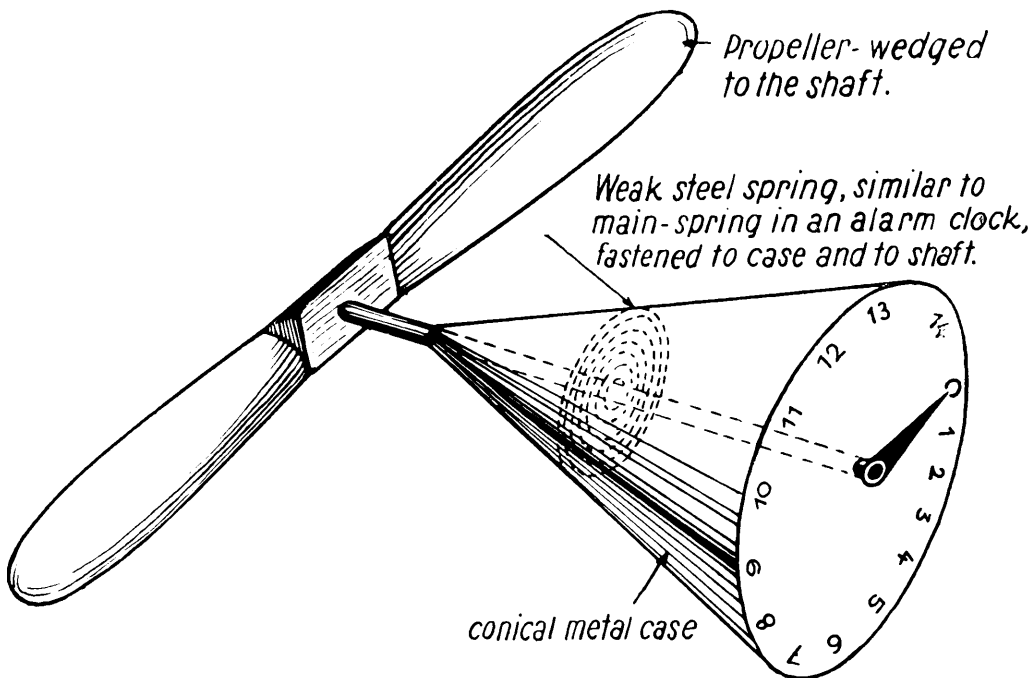

FIG. 81.

Home-made speed indicator.

What would become of a hapless airman who, trained to fly according to instruments only, suddenly

discovered that his speed indicator had ceased to register ?

A height indicator is an instrument which every sail-planer must have. Anyone can guess the altitude at which he is, but only roughly.

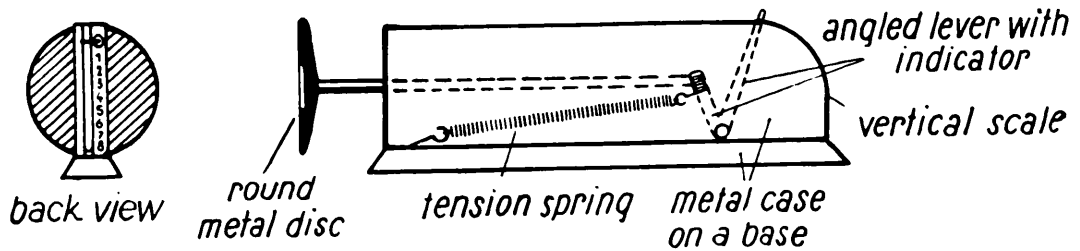

FIG. 82.

Home-made speed indicator.

The height indicator is a barometer which indicates variations in atmospheric pressure. The ground barometer indicates this pressure in millimetres on a column of quicksilver—even the aneroid records by this method. The height indicator used in a flying machine registers variations in pressure in metres. It is common knowledge that atmospheric pressure decreases proportionately as the altitude increases. Consequently, recorded variations in atmospheric pressure can also be read straightway in metres as so much altitude lost or gained (fig. 83).

As a height indicator of this type is sensitive to varying weather conditions and registers both high

and low atmospheric pressure, it should always be set to register zero at the altitude of the starting-point.

Especially in sail planing, it is very necessary for the airman to know at what height he is above the ground, and with the aid of a height indicator he

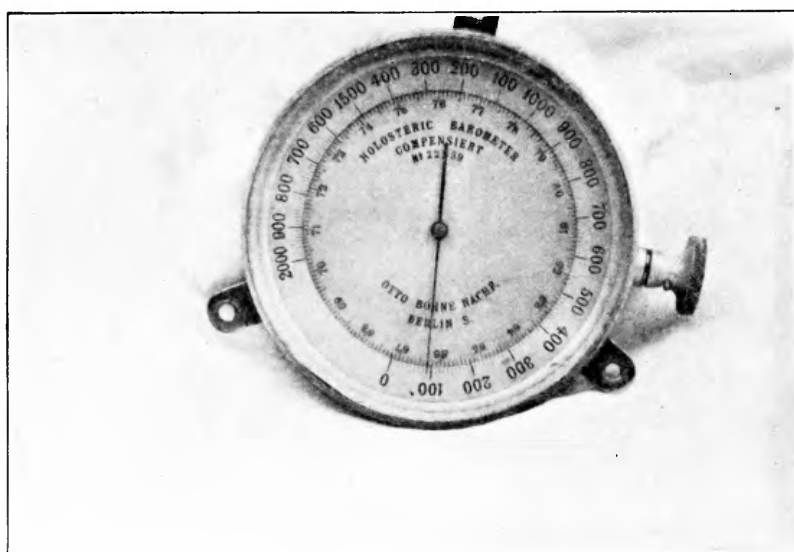

FIG. 83.
Height indicator.

can not only do this, but can tell whether he is ascending or descending. This is important, because one quickly loses the sense of ascending or descending motion when it becomes leisurely and continuous. An instrument called a variometer exists for the purpose of indicating ascent and

descent and is much used in balloons. It is, unfortunately, large and unwieldy and fails to register immediately a change takes place. Another instrument, constructed according to the law of inertia, merely registers that acceleration which one would notice in any case from the pilot's seat.

For competitive flying or tests of skill, a barograph, or recording barometer, may be used. This is a type of height indicator which shows graphically the course taken by the machine. A recording needle writes the variations in height on paper graduated vertically in metres (fig. 84).

There exist also so-called side-slip indicators which work on the pendulum principle. These are superfluous in fine weather, as the airman can then see whether the machine is side-slipping or not. In fog, when such an indicator would be of real value, it proves useless as it is subject to centrifugal forces. If, for example, the airman unwittingly performs a curve, as he is liable to do, when fog has obliterated his position point, the side-slip indicator continues to register normal position because the pendulum or the fluid in the level are subject to centrifugal force. It may be argued that nobody

would dream of sail-planing in fog, but it must be remembered that modern sail-planing is closely connected with cloud flying and when the airman is in a cloud he is in fog or mist.

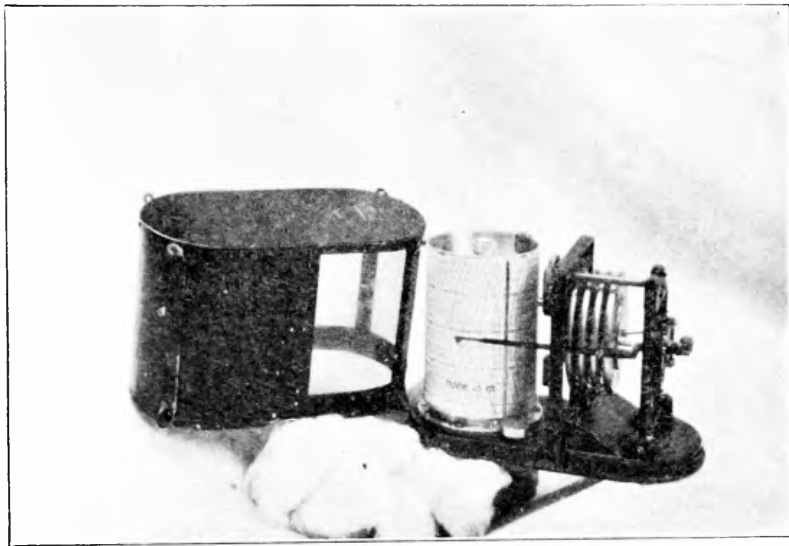

FIG. 84.
Barograph (open).

One instrument of essential importance in fog is the compass. If the airman succeeds in holding his course, he runs little risk of performing involuntary turns, which, among clouds, might possibly lead to disaster. Unfortunately even the compass can afford only limited assistance, as the electric influences present in cloud formations cause magnetic variation.

Instruments constructed for engine-driven planes, as, for example, the gyroscope or the level compass, are entirely unsuitable for sail-planing by reason of their large dimensions and complicated mechanism.

The instruments required by an expert sail-planer are, therefore: speedometer, height indicator and compass, with the possible addition of a variometer. The beginner's instruments must be his eyes, his ears and his sense of equilibrium.

What's Wrong with Your Game ?

by H. B. MARTIN
(author of "Pictorial Golf")

WITH OVER 100 SKETCHES AND ILLUSTRATIONS

7s. 6d.

"This book is one of the most helpful 'life lines' thrown out for a long time. It is simply expressed and the author has the great asset of being able to explain his ideas and theories with lucidity—and so few golf theorists can do that. Mr. Martin can be technical and yet plain, and that again is a rare gift. The illustrations are numerous and extremely good. By a close study of them, referring to the accompanying text, a keen golfer could hardly fail to improve his game. 'What's Wrong with Your Game?' is a notable addition to the literature of golf. It is well written, easy to read and genuinely helpful."—*Daily News*.

Defence at Auction Bridge

by J. R. ADAMS

5s.

In the numerous books that have been written on Auction Bridge the vital question of defence tactics is generally either ignored or relegated to one chapter. Mr. Adams has set out in this book to remedy this defect and has covered the whole subject in an extremely thorough, lucid and attractive manner. All bridge-players, whether beginners or more advanced players, will get something of value from this book, which is well illustrated with numerous actual hands and cases, and brings wide experience and sound reasoning to bear on the problem.

THE WEEK-END LIBRARY

A Series of reprints of books of established reputation
produced in uniform style and in a pocket size

3s. 6d. net each volume.

- THE HANDLING OF WORDS *By* VERNON LEE
ORTHODOXY *By* G. K. CHESTERTON
THE TWILIGHT OF THE GODS *By* RICHARD GARNETT
SCHOLAR-GIPSIES *By* JOHN BUCHAN
SELECTED STORIES OF ANATOLE FRANCE
SOME EXPERIENCES OF A NEW GUINEA RESIDENT
MAGISTRATE : First and Second Series *By* C. A. W. MONCKTON
WITH SILENT FRIENDS *By* RICHARD KING
HORTUS VITÆ *By* VERNON LEE
UNADDRESSED LETTERS *By* SIR FRANK SWETTENHAM
CANADIAN WONDER TALES *By* CYRUS MACMILLAN
BEHIND THE BEYOND *By* STEPHEN LEACOCK
THE FUGGER NEWS-LETTERS : First Series
Edited by VICTOR VON KLARWILL
THE GOOD SOLDIER *By* FORD MADOX FORD
HERETICS *By* G. K. CHESTERTON
THE ENGLISH COMIC CHARACTERS *By* J. B. PRIESTLEY
INTERLUDES AND POEMS *By* LASCELLES ABERCROMBIE
THE ROMANCE OF EXCAVATION *By* DAVID MASTERS
THE NAPOLEON OF NOTTING HILL *By* G. K. CHESTERTON
CANADIAN FAIRY TALES *By* CYRUS MACMILLAN
REMINISCENCES OF SCOTTISH LIFE AND CHARACTER
By DEAN RAMSAY
ADVENTURES IN BOLIVIA *By* C. H. PRODGERS
SECOND BOOK OF SILENT FRIENDS *By* RICHARD KING
FIGURES IN MODERN LITERATURE *By* J. B. PRIESTLEY
SKETCHES OF ENGLISH LIFE AND CHARACTER
By MARY RUSSELL MITFORD
THE STORY OF LONDON'S GREAT FIRE *By* WALTER G. BELL
LONDON NIGHTS *By* STEPHEN GRAHAM
ARIEL *By* ANDRÉ MAUROIS
THE ESCAPING CLUB *By* A. J. EVANS
THE WONDERS OF SALVAGE *By* DAVID MASTERS
A VERNON LEE ANTHOLOGY : Selections from the earlier
works made *By* IRENE COOPER WILLIS
THE SILENCE OF COLONEL BRAMBLÉ *By* ANDRÉ MAUROIS
THE WORLD WITHOUT AND THE WORLD WITHIN :
First and Second Series *By* THEODORA THOMPSON
ELDER CONKLIN *By* FRANK HARRIS
MONTES THE MATADOR *By* FRANK HARRIS
THE ROAD TO EN-DOR *By* E. H. JONES
THE GOLDEN AGE *By* KENNETH GRAHAME
WORKS AND MORE *By* MAX BEERBOHM
ARIADNE IN MANTUA *By* VERNON LEE

Other volumes in preparation

JOHN LANE THE BODLEY HEAD LTD., VIGO STREET, W.1

GLIDING AND SAIL-PLANING

A Beginner's Handbook

by F. STAMER and A. LIPPISCH



The motorless aeroplane, now known as the Glider or Sail-Plane, is rapidly growing in popularity, especially among the younger generation, and gliding and sail-planing is clearly going to be *the* air-sport of the future. First popularised in Germany, the sport has now taken firm root in England, especially since the visit of the German gliders, Herren Kronfeld and Magersuppe, and gliding clubs are everywhere springing up.

This book, by two well-known German experts, is the first exhaustive handbook on the sport to be published in this country, and will be indispensable to all who are going to take up gliding and sail-planing. It covers the whole ground—equipment and training, choice of ground, practice flying, clouds and winds, tools, construction and maintenance.

With 84 illustrations and diagrams.

5s. net.



JOHN LANE THE BODLEY HEAD LTD., VIGO ST.,
LONDON, W.1.